



STACO SWITCH

a STACO, INC. company

1139 BAKER STREET, COSTA MESA, CALIF. 92626
(714) 549-3041 TWX: 910/595-1507

TECHNICAL BULLETIN 12-A-9

Recommended Panel Cut-Outs for Multiple Pushbutton Guards

Occasionally there are applications in which two or more adjacent switches will require pushbutton guards. In these instances the panel cut-outs must be spaced to allow for the width and/or length of the frame of the pushbutton guard. Shown below are recommended cut-outs for mounting switches side by side and above or below adjacent switches, all with pushbutton guards. Recommended cut-out spacing for mounting a single switch with pushbutton guard next to switches without guards can also be determined from the drawings.

Recommended cut-outs are shown for Part No. 15007 for square pushbuttons, Part No. 15055 for rectangular pushbuttons, and Part No. 15070 for square extended pushbuttons.

Recommended panel cut-out for multiple square pushbutton guards, Part No. 15007.

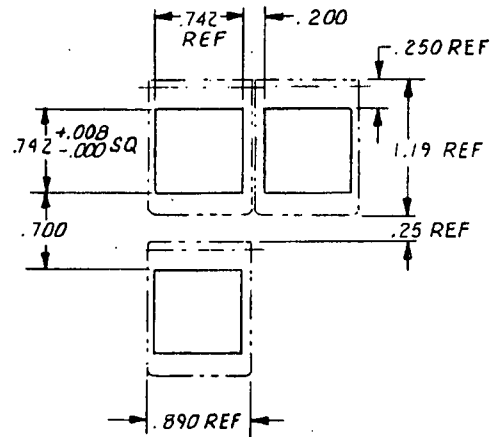

Recommended panel cut-out for multiple rectangular pushbutton guards, Part No. 15055.

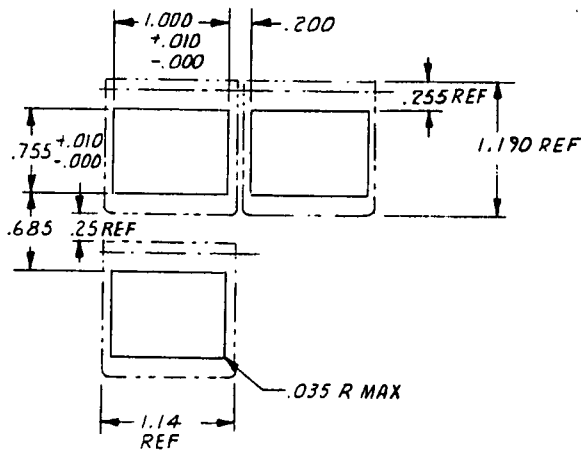

Recommended panel cut-out for multiple square extended pushbutton guards, Part No. 15070.

