

## LED LIGHTING REQUIREMENTS OF 1X6 KEYPADS

The keypad may be lighted using various voltage sources as long as a current limiting circuit is provided. The recommended current limiting circuit includes user-supplied resistors as shown on the following figures. The  $V_S$  is the voltage source, and pin 1 through pin 7 are the pins of green and red LED lighting connectors.

The recommended resistor value for the green LED lighting connector ( $R_G$ ), resistor value for the red LED lighting connector ( $R_R$ ), minimum resistor power rating for the green LED lighting connector ( $P_{RG}$ ), minimum resistor power rating for the red LED lighting connector ( $P_{RR}$ ) for a given power supply voltage source ( $V_S$ ) are shown on the following tables. Also shown are the minimum power supply power rating ( $P_S$ ).

If the voltage source is not listed on the tables,  $P_S$ ,  $R_G$ ,  $R_R$ ,  $P_{RG}$ , and  $P_{RR}$  are determined by evaluating the equations which follow. The following equations are derived for a lighted 1X6 keypad that has six (n) pushbuttons (LEDs) with 20 mA forward current (i) per LED, 2.0 V green LED forward voltage ( $V_{LG}$ ), and 1.7 V red LED forward voltage ( $V_{LR}$ ).

### Recommended Power Supply and Resistor to Individually Light Each Pushbutton

A pushbutton LED is lighted by grounding its cathode.

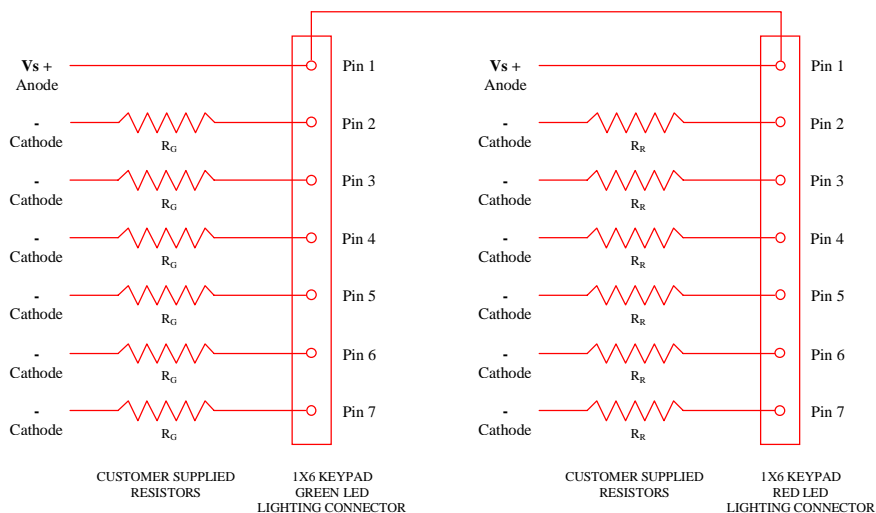

### Resistors to Light Individual Pushbutton Green or Red

#### Power Supply and Resistor to Light Individual Pushbutton Green or Red

Power Supply		Resistor for Green LED		Resistor for Red LED		Pushbutton		Green LED	Red LED
$V_S$ (V)	$P_S$ min (W)	$R_G$ ( $\Omega$ )	$P_{RG}$ min (W)	$R_R$ ( $\Omega$ )	$P_{RR}$ min (W)	TOTAL (n)	i (A)	$V_{LG}$ (V)	$V_{LR}$ (V)
5	0.60	150	0.06	165	0.07	6	0.02	2.0	1.7
12	1.44	500	0.20	515	0.21	6	0.02	2.0	1.7
14	1.68	600	0.24	615	0.25	6	0.02	2.0	1.7
28	3.36	1300	0.52	1315	0.53	6	0.02	2.0	1.7

Rev.	Rel. ER	Date
NC	02-38957	

Sheet	of
1	2

### Power Supply and Resistor Equations to Light Individual Pushbutton

$$P_S = niV_S$$

$$R_G = \frac{V_S - V_{LG}}{i}$$

$$R_R = \frac{V_S - V_{LR}}{i}$$

$$P_{RG} = i^2 R_G$$

$$P_{RR} = i^2 R_R$$

### Recommended Power Supply and Resistor to Simultaneously Light All Pushbuttons

**NOTE:**

Since the anodes of the green LEDs and the anodes of the red LEDs are tied together to pin 1 green LED lighting connector and pin 1 red LED lighting connector, each current limiting resistor has to be placed on the cathode side of the connector. The pushbuttons are lighted by bringing the cathode to ground.

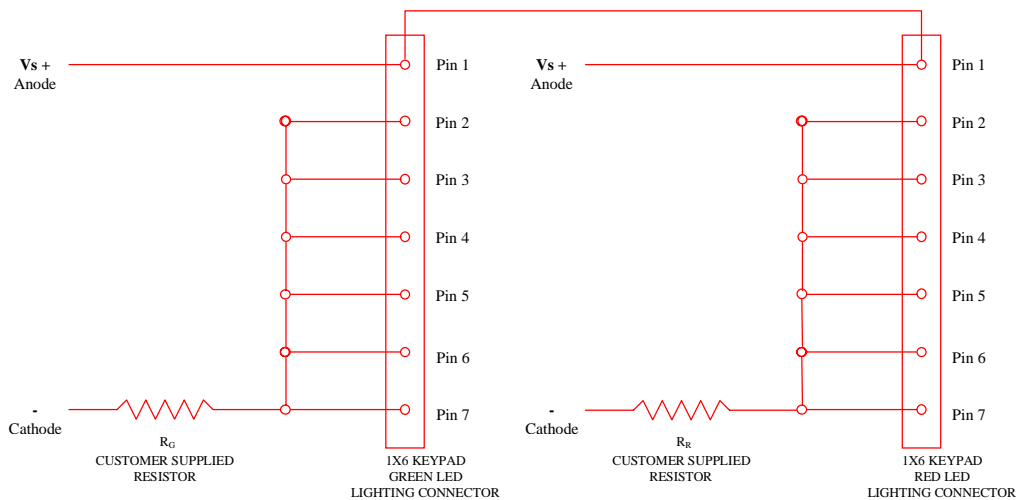

### Resistors to Light All Pushbuttons Green or Red

### Power Supply and Resistor to Light All Pushbuttons Green or Red

Power Supply		Resistor for Green LED		Resistor for Red LED		Pushbutton		Green LED	Red LED
V <sub>S</sub> (V)	P <sub>S</sub> min (W)	R <sub>G</sub> (Ω)	P <sub>RG</sub> min (W)	R <sub>R</sub> (Ω)	P <sub>RR</sub> min (W)	TOTAL (n)	i (A)	V <sub>LG</sub> (V)	V <sub>LR</sub> (V)
5	0.60	25.00	0.36	27.50	0.40	6	0.02	2.0	1.7
12	1.44	83.33	1.20	85.83	1.24	6	0.02	2.0	1.7
14	1.68	100.00	1.44	102.50	1.48	6	0.02	2.0	1.7
28	3.36	216.67	3.12	219.17	3.16	6	0.02	2.0	1.7

### Power Supply and Resistor Equations to Light All Pushbuttons

$$P_S = niV_S$$

$$R_G = \frac{V_S - V_{LG}}{ni}$$

$$R_R = \frac{V_S - V_{LR}}{ni}$$

$$P_{RG} = (ni)^2 R_G$$

$$P_{RR} = (ni)^2 R_R$$