

BAILING CIRCUIT FOR SOLENOID HELD SWITCHES

To provide a multi-station switching system or remote location control capability, a bailing circuit may be used as shown in Fig. 1. This circuit offers a means of using any number of solenoid held pushbutton switches in a one-by-one sequence in situations requiring that only one switch be operated at a time. Actuation of any switch automatically releases any other pushbutton previously held in the down position by the solenoid coil.

A "cancel" switch may be installed at either of points "A" or "B" to perform clearing of all switches. It may be a momentary switch for quick clearing or an alternate action switch for "off-on" operation.

This circuit offers design advantages because mechanical release systems are not needed to accomplish the "bailing" action.

A suitable diode should be placed in parallel with the solenoid coil to suppress any high voltage spikes induced by switching an inductive load. This will minimize damage to the switch contacts caused by arcing. Recommended diodes are: IN4002 (axial lead) or DL4002 (surface mount). Source: DIODES INC.

FIGURE 1

(Lamp circuits omitted for clarity)

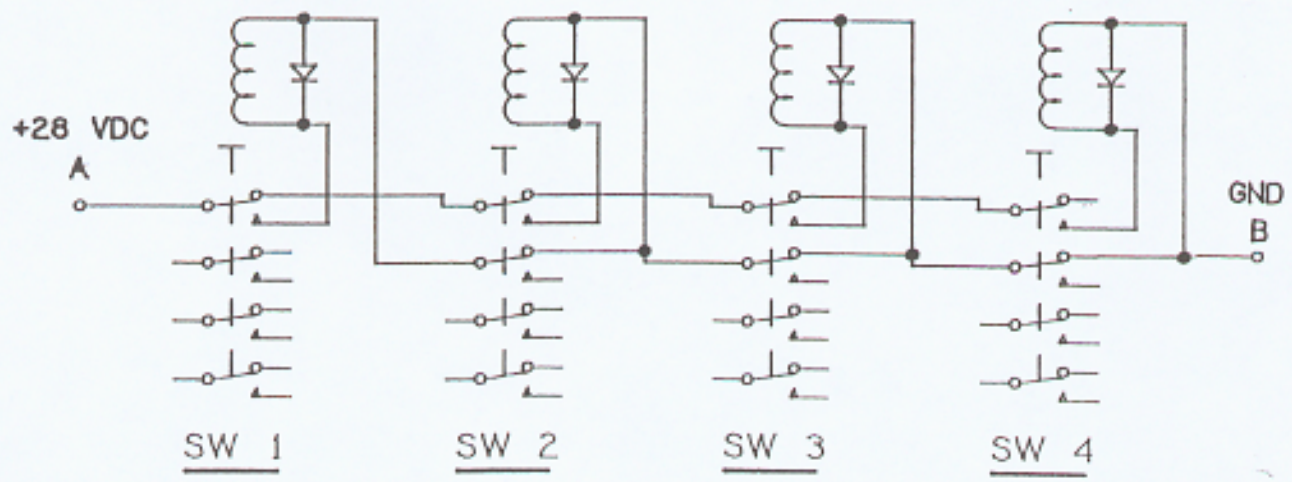

Rev.	Rel. ER	Date
A	01-38276	2-26-00