

PHONE:  
(714)549-3041

FAX:  
(714)549-0930



1139 BAKER ST.  
COSTA MESA, CA.  
92626

A Components Corporation of America Company

© Copyright StacoSwitch  
Inc., 2002

CAGE CODE: **12522**

	NAME	DATE
ORIGINATOR	A. KERTATAMA	29JL02
APPROVED	<i>[Signature]</i>	7-29-02
APPROVED	<i>[Signature]</i>	7/29/2002

**Part of the M7 Family of  
MET Data Entry Products**

**Series M717**

# PC-COMPATIBLE KEYBOARDS

*Panel Mount*

88-Key with Encoder,  
NEMA 4 Sealing  
and optional LED Lighting

SERIES M717 CODED

SERIES M717 CODED

NC

SHEET 1 OF 25

The Information and design disclosed herein was originated by and is the property of STACOSWITCH, INC. STACOSWITCH, INC. reserves all patent, proprietary, design, manufacturing, reproduction, use and sale rights thereto, and to any article disclosed therein, except to the extent fights are expressly granted to others. The foregoing does not apply to vendor proprietary parts.



## TABLE OF CONTENTS

1.0 SCOPE.....	5
2.0 SERIES M717 PC-COMPATIBLE PANEL MOUNT KEYBOARDS .....	6
2.1 PRODUCT FEATURES/OPTIONS .....	6
2.2 PANEL MOUNT KEYBOARD .....	6
2.3 COLOR .....	6
2.4 LIGHTING .....	6
2.4.1 Backlighting Option.....	6
2.4.2 Status Indicators .....	7
3.0 REQUIREMENTS .....	8
3.1 DIMENSIONS.....	8
3.1.1 Panel Cutouts and Mounting.....	8
3.1.1.1 Surface Mount Application.....	8
3.1.1.2 Rear Mount Application .....	10
3.1.2 Mounting Torque.....	12
3.2 PRESSURE RELIEF .....	12
3.3 INTERFACE CONNECTION .....	12
3.3.1 Keyboard Connection .....	13
3.3.2 LED Electrical Connection and Power Requirements .....	13
3.4 LED BRIGHTNESS.....	15
3.4.1 Increasing LED Brightness.....	15
3.4.2 Decreasing LED Brightness .....	15
3.5 ELECTRICAL PERFORMANCE REQUIREMENTS .....	15
3.6 MECHANICAL PERFORMANCE .....	16
3.6.1 Weight.....	16
3.6.2 Mechanical Life .....	16
3.6.3 Force Travel Curve.....	17
3.7 ENVIRONMENTAL REQUIREMENTS .....	17
3.7.1 Temperature Range.....	17
3.7.2 Thermal Shock.....	18
3.7.3 Vibration .....	18
3.7.4 Shock .....	18
3.7.5 Moisture Resistance.....	18
3.7.6 NEMA 4.....	18
3.7.7 Salt Spray.....	19
3.7.8 Sand and Dust .....	19
3.7.9 Legend Chemical Resistance .....	19
3.7.10 Legend Wear .....	20
3.7.11 Legend Adhesion .....	20
3.7.12 Finger Print Resistance.....	20

CAGE CODE:	DRAWING NO.	REV.	SHT.
<b>12522</b>	SERIES M717 CODED	NC	3

3.8 MATERIAL REQUIREMENT.....	20
3.8.1 Corrosion Resistance .....	20
3.8.2 Fungus.....	20
3.8.3 Terminal Plating.....	21
3.9 OTHER REQUIREMENTS.....	21
3.9.1 Marking.....	21
3.9.2 Workmanship.....	21
3.9.3 Quality.....	21
3.9.4 Changes In Specification.....	21
 4.0 PART NUMBER INFORMATION.....	 22
4.1 M717 PANEL MOUNT KEYBOARDS .....	22
4.2 ACCESSORIES .....	23
4.2.1 Rear Panel Mounting Brackets.....	23
4.2.2 Mating Connector Kit.....	23
4.2.3 Crimping Tool .....	23
4.2.4 Extractor Tool .....	24
4.2.5 Keyboard Lighting Power Supplies .....	24
4.2.5.1 Wall Mount Power Supply.....	24
4.2.5.2 Desktop Power Supply .....	24
4.2.6 Keyboard Cable .....	24
4.2.7 Lighting Cable .....	25
4.2.8 Lighting Cable with Ferrite Bead.....	25
4.2.9 Keyboard Cable with Ferrite Beads .....	25
4.2.10 PC/AT Keyboard Adapter.....	25

CAGE CODE:	DRAWING NO.	REV.	SHT.
<b>12522</b>	<b>SERIES M717 CODED</b>	<b>NC</b>	<b>4</b>

PRODUCT LINE SPECIFICATION

SERIES M717

**PC-COMPATIBLE KEYBOARDS**

Panel Mount

**1.0 SCOPE**

This Specification Control Document (SCD) describes the detailed characteristics of one of the M7 Family of data entry devices utilizing Molded Elastomer Technology (MET). The products emanating from this SCD are designated as product series M717.

Specifically, the M717 includes a Qwerty panel mount keypad. LED lighting of the keyboard is also available as an option. The keyboard has 88 physical keys as to be equivalent to an 87-key PC-compatible keyboard, and two additional keys to control the brightness of the keyboard LEDs. Incorporated into the keyboard is an encoder to translate key strokes into standard PS/2 codes, and a 32 discrete LED brightness levels adjuster. The keyboard is PS/2 and PC/AT compatible. The surface mounted panel mount keyboard meets NEMA 4 requirements.

Accessory items for the panel mount keyboard are rear panel mounting bracket, mating connector kits, crimping tool, extraction tool, power supplies for the lighted keyboards, lighting cable, keyboard cable, cables with ferrite beads, and PC/AT keyboard adapter.

CAGE CODE:	DRAWING NO.	REV.	SHT.
12522	SERIES M717 CODED	NC	5

## 2.0 SERIES M717 PC-COMPATIBLE PANEL MOUNT KEYBOARDS

### 2.1 Product Features/Options

The PC-compatible panel mount keyboard is designed to be rugged and durable, yet provide modern styling with adjustable LED brightness. It is available in a choice of two colors. Backlighting with green LEDs is available as an option.

### 2.2 Panel Mount Keyboard

The panel mount keyboard has 88 physical keys as shown in Figure 2.1. The keyboard has a built-in encoder that allows the keyboard to be connected to an IBM PC PS/2 or PC/AT port. The keyboard has laser engraved legends. The keyboard is a plug and play device.

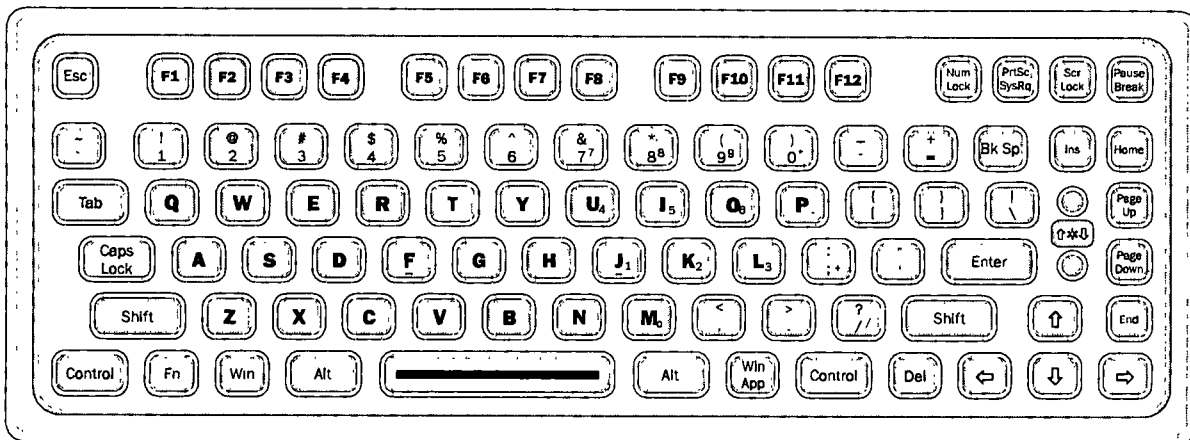

Figure 2.1  
Panel Mount Keyboard

### 2.3 Color

Two keyboard colors are available. The key legend color is white.

### 2.4 Lighting

The brightness of the backlighting and status indicator LEDs is adjusted by the round buttons.

#### 2.4.1 Backlighting Option

When the option is specified, the lighted keyboard is equipped with green LEDs under each key for background lighting.

CAGE CODE:	DRAWING NO.	REV.	SHT.
12522	SERIES M717 CODED	NC	6

## 2.4.2 Status Indicators

All keyboards are equipped with Caps Lock, Num Lock and Scroll Lock red LED indicators.

CAGE CODE:	DRAWING NO.	REV.	SHT.
12522	SERIES M717 CODED	NC	7

### 3.0 REQUIREMENTS

This specification defines the detailed requirements for the M717 panel mount keyboard. For all tests specified in this document, the test sample shall be mounted in such a manner as to simulate in-service use unless the specific test method precludes such mounting.

### 3.1 Dimensions

The panel mount keyboard outline dimensions are shown in Figure 3.1.

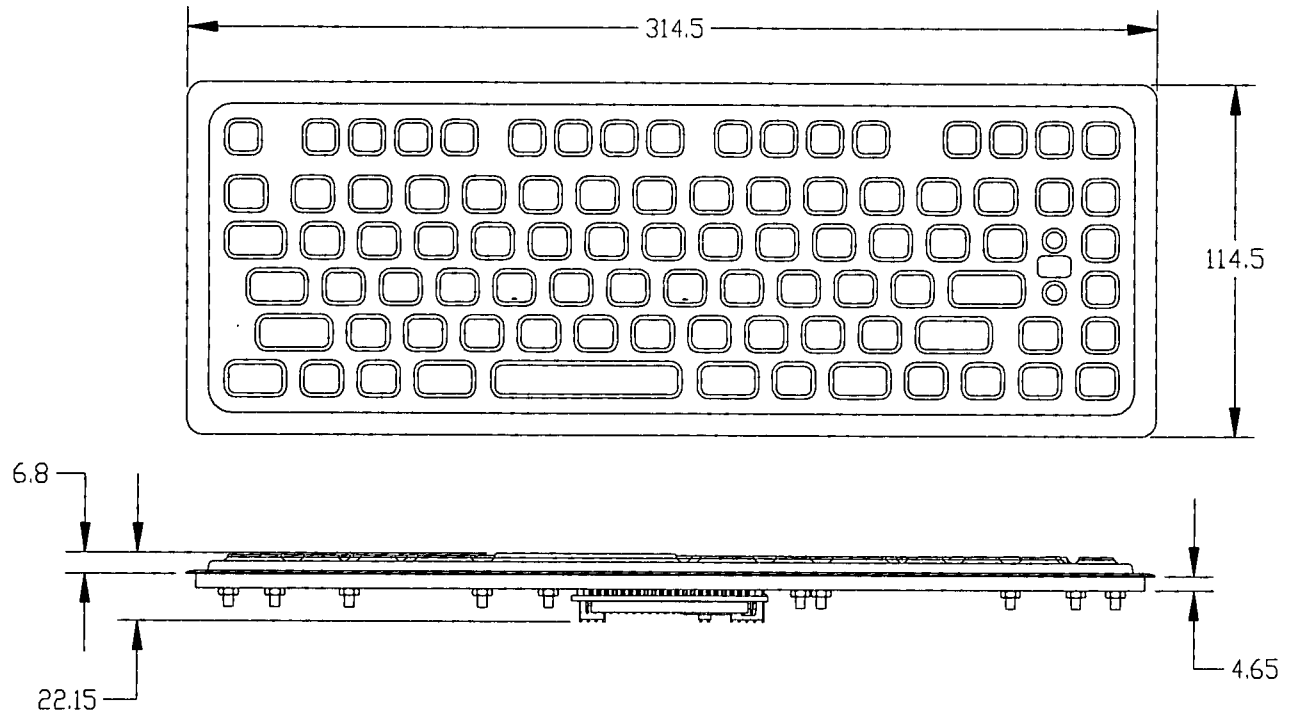

DIMENSIONS ARE IN MILLIMETERS.

Figure 3.1  
Panel Mount Keyboard Outline Dimensions

#### 3.1.1 Panel Cutouts and Mounting

The panel mount keyboard is designed for either surface mount application or rear mount application.

##### 3.1.1.1 Surface Mount Application

Figures 3.2 and 3.3 show panel cutout recommendation for surface mounting a panel mount keyboard.

CAGE CODE:	DRAWING NO.	REV.	SHT.
12522	SERIES M717 CODED	NC	8

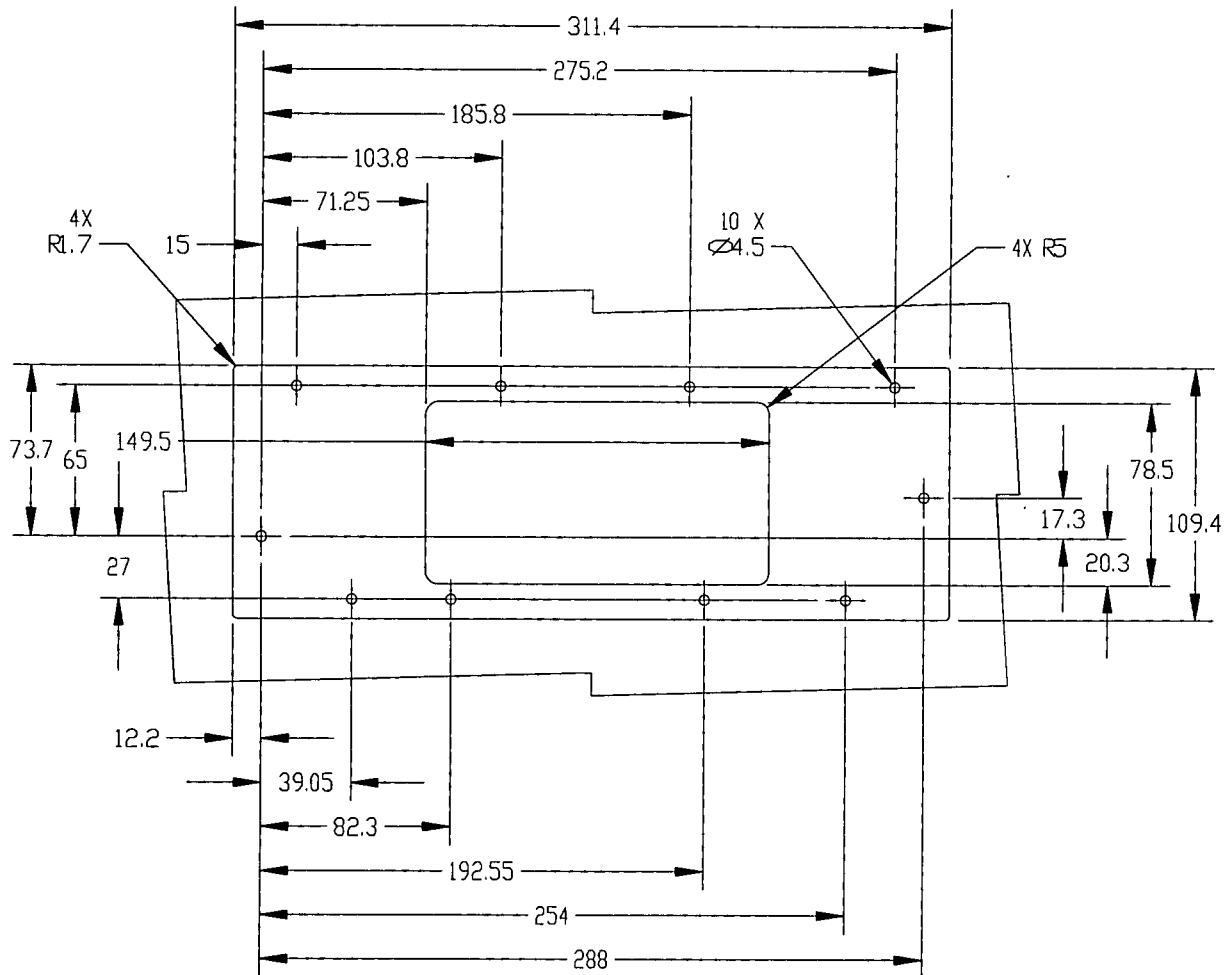
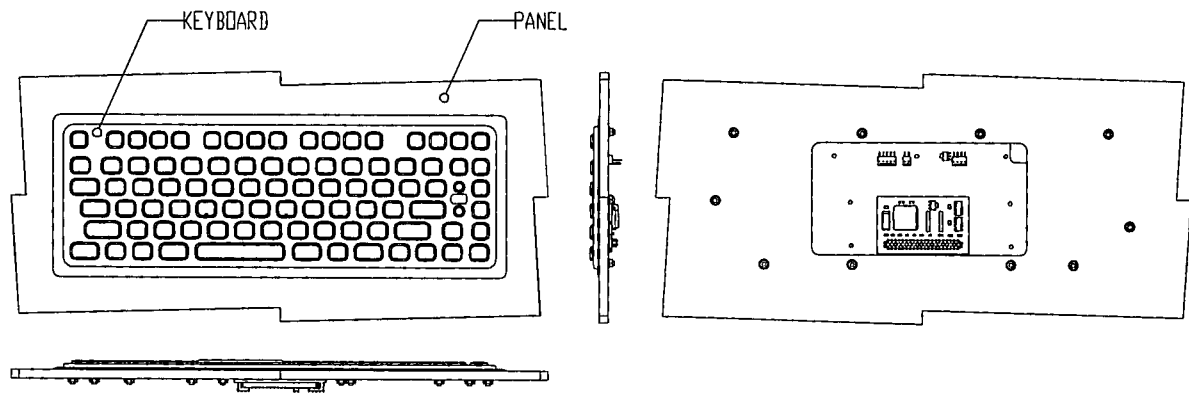

DIMENSIONS ARE IN MILLIMETERS.

Figure 3.2  
**Panel Cutout Recommendation for Surface Mounting a Panel Mount Keyboard**

CAGE CODE:	DRAWING NO.	REV.	SHT.
12522	SERIES M717 CODED	NC	9

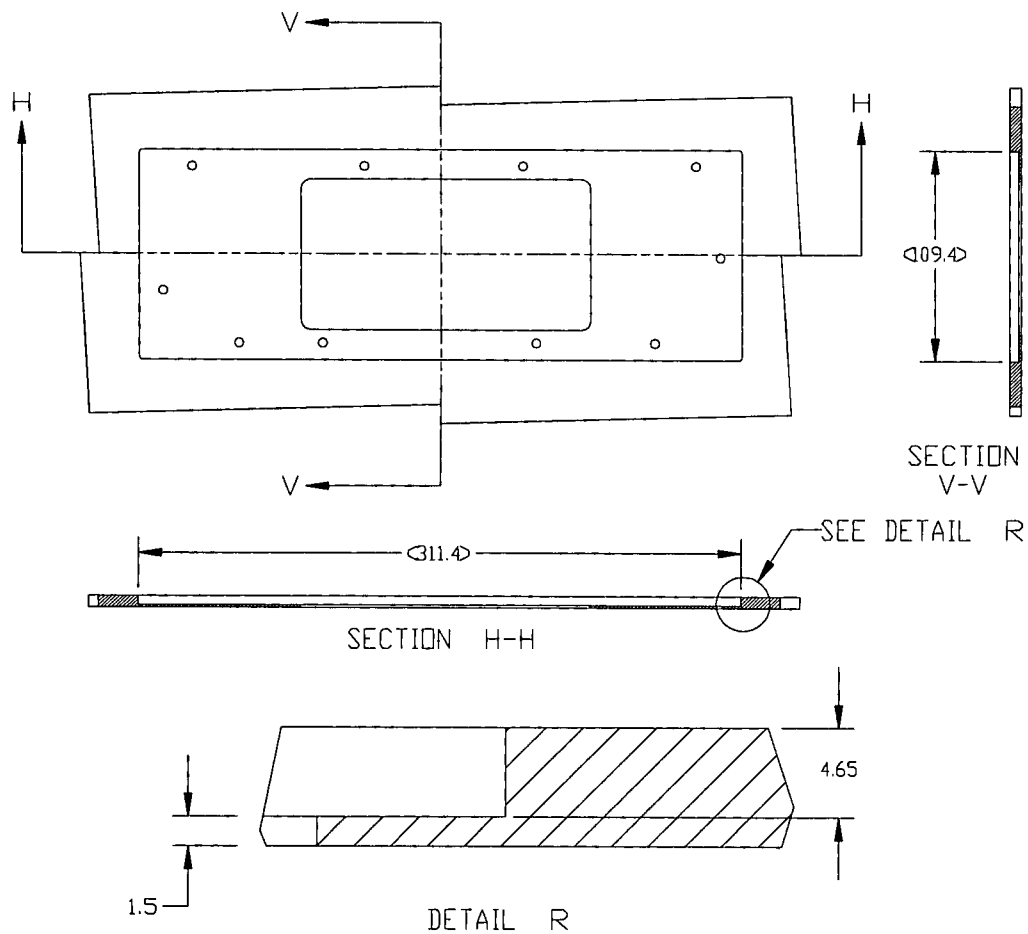

DIMENSIONS ARE IN MILLIMETERS.

**Figure 3.3**  
**Section and Detail Views of Panel Cutout Recommendation**  
**for Surface Mounting a Panel Mount Keyboard**

**3.1.1.2 Rear Mount Application**

Figure 3.4 shows the panel cutout and hardware recommendation for rear mounting a panel mount keyboard.

CAGE CODE:	DRAWING NO.	REV.	SHT.
12522	SERIES M717 CODED	NC	10

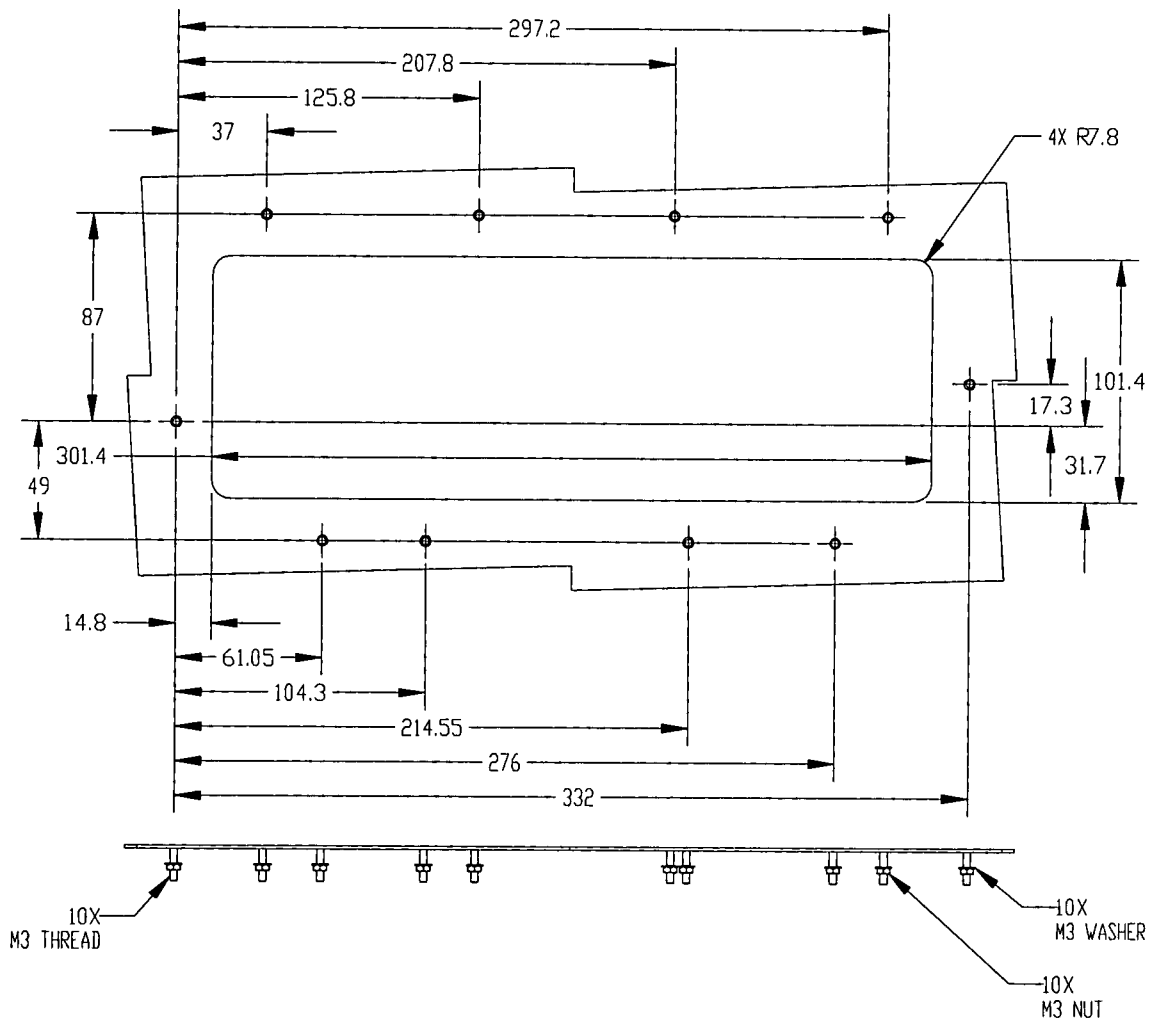
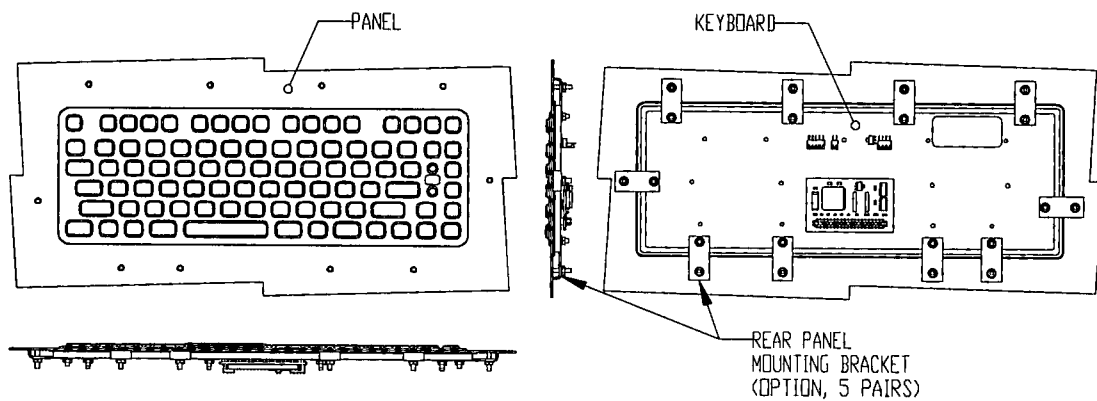

DIMENSIONS ARE IN MILLIMETERS.

Figure 3.4  
**Panel Cutout and Hardware Recommendation for  
 Rear Mounting a Panel Mount Keyboard**

CAGE CODE:	DRAWING NO.	REV.	SHT.
12522	SERIES M717 CODED	NC	11

### 3.1.2 Mounting Torque

The recommended torque to be applied to the nuts during installation is  $0.60 \pm 0.02$  Nm ( $5.31 \pm 0.18$  lbf in).

### 3.2 Pressure Relief

When the panel mount keypad is mounted on a NEMA 4 enclosure, the enclosure should have a pressure relief feature. The pressure relief feature is required to equalize the air pressure inside the enclosure to the surrounding atmosphere.

### 3.3 Interface Connection

The connections to the panel mount keyboard are through standard .100 inches (2.54 mm) pitch centerline connector system. The keyboard has two .025 inches (0.64 mm) square pin friction lock headers for keyboard and lighting connections. The connectors are shown on Figure 3.5. The .100 inches (2.54 mm) center header pins are gold plated.

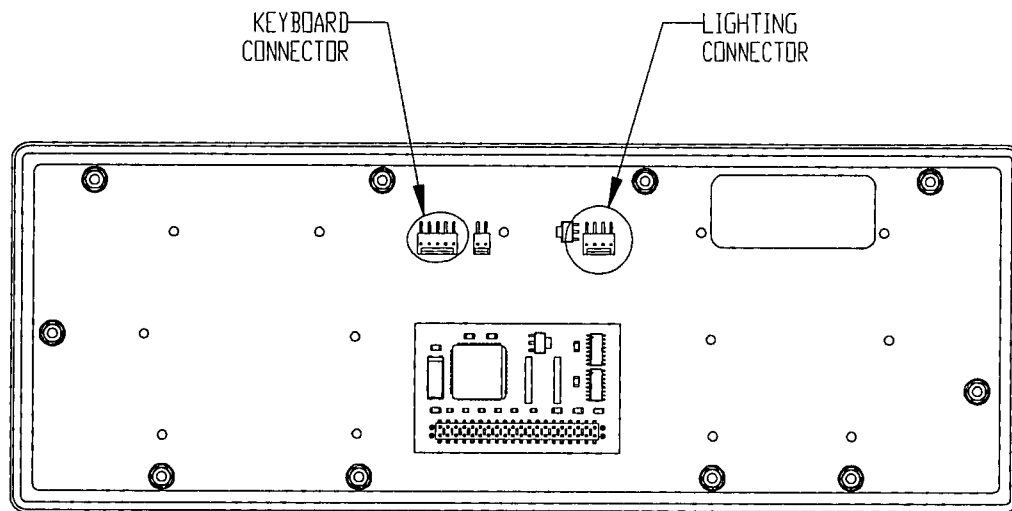

Figure 3.5  
Connector

The mating connector of the keyboard should have a .100 inches (2.54 mm) center crimp terminal housing. It is recommended that the crimp housing has polarizing ribs and locking ramp. Mating connector kits are available for these and other accessories, see Section 4.2. Users must provide their own strain relief for severe vibration requirements.

CAGE CODE:	DRAWING NO.	REV.	SHT.
12522	SERIES M717 CODED	NC	12

### 3.3.1 Keyboard Connection

Figure 3.6 shows the pin numbers of a keyboard connector, and Table 3.1 shows the function of each pin. Keyboard cable and cable with ferrite beads are available, as described in section 4.2, to conveniently connect a panel mount keyboard to an IBM PS/2 keyboard port.

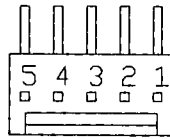

Figure 3.6  
**Keyboard Connector Pin Number**

Table 3.1  
**Keyboard Connector Pin Number and Function**

Pin Number	Function
1	V <sub>CC</sub>
2	GND
3	Shield
4	KD (Keyboard Data)
5	KC (Keyboard Clock)

The pin numbers/assignments of unlighted and lighted panel mount keyboards are the same.

### 3.3.2 LED Electrical Connection and Power Requirements

The connection to the panel mount keyboard LEDs is shown on Figure 3.7. The keyboard has 95 LEDs connected in parallel through a 4-pin connector. Pins 1 and 2, which are tied together, supply the anodes of the LEDs. The cathodes are connected to pins 3 and 4 as shown in Table 3.2. The user is to supply the current limiting circuit.

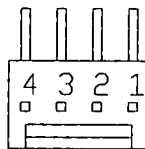

Figure 3.7  
**Lighting Connector**

CAGE CODE:	DRAWING NO.	REV.	SHT.
12522	SERIES M717 CODED	NC	13

Table 3.2  
**Lighting Pin Number and Function**

Pin Number	Function
1	Anode
2	Anode
3	Cathode
4	Cathode

Power requirements to light the keyboard are 1.9 A at 2.1 VDC for a total power requirement of 3.99 W at full brightness. To conveniently and efficiently meet the lighting power requirements, a choice of two AC power converters are available. See section 4.2 for keyboard lighting power supplies and cabling.

The keyboard may be lighted using various voltage sources as long as a current limiting circuit is provided. The recommended current limiting circuit includes user-supplied resistor as shown on Figure 3.8. The  $V_s$  is the voltage source, and pin 1 through pin 4 are the keyboard lighting connector.

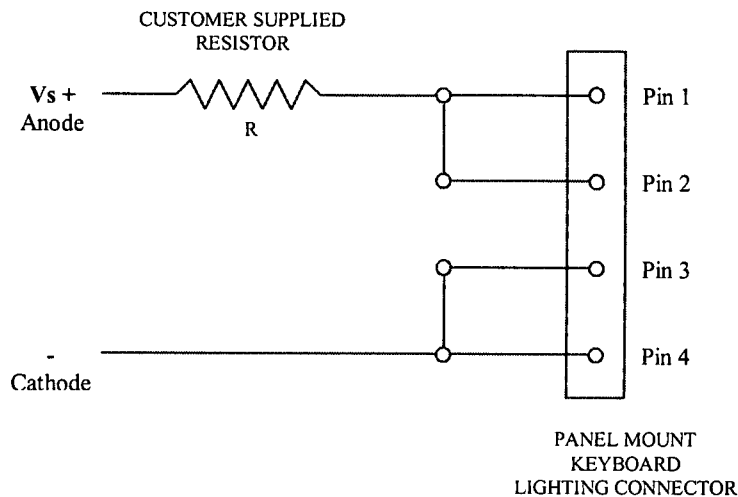

Figure 3.8

**Keyboard User Supplied Resistor for Lighting**

The recommended resistor value ( $R$ ) and minimum resistor power rating ( $P_R$ ) for a given power supply voltage ( $V_s$ ) are shown on Table 3.3. Also shown are the minimum power supply power ratings ( $P_s$ ).

CAGE CODE:	DRAWING NO.	REV.	SHT.
12522	SERIES M717 CODED	NC	14

**Table 3.3**  
**Recommended Resistor for Keyboard LEDs**

DC Power Supply		Resistor		Keyboard i (A)	LED V <sub>L</sub> (V)
V <sub>s</sub> (V)	P <sub>s</sub> min (W)	R (Ω)	P <sub>R</sub> min (W)		
2	3.8	0.00	0.0	1.9	2.0
5	9.5	1.58	5.7	1.9	2.0
12	22.8	5.26	19.0	1.9	2.0
14	26.6	6.32	22.8	1.9	2.0
28	53.2	13.68	49.4	1.9	2.0

If the voltage source is not listed on Table 3.3, the minimum power supply power rating, resistor value, and the minimum resistor power rating are determined by evaluating the equations that follow. The following equations are derived for a panel mount keyboard LEDs that requires 1.9 A typical current (i), and 2.0 V LED forward voltage (V<sub>L</sub>). The maximum green LED voltage is 2.6 V.

$$R = \frac{V_s - V_L}{i}$$

$$P_R = i^2 R$$

$$P_s = i V_s$$

### 3.4 LED Brightness

The LEDs brightness is set at 50% level when the computer is booted. The time required to increase the brightness from 50% to 100% (full brightness, On) is about 1.5 seconds, and the time required to decrease (dim) the brightness from 50% to 0% (minimum brightness, Off) is also about 1.5 seconds.

#### 3.4.1 Increasing LED Brightness

The LED brightness is increased by pressing the round button above the  indicator.

#### 3.4.2 Decreasing LED Brightness

The LED brightness is decreased by pressing the round button below the  indicator.

CAGE CODE:	DRAWING NO.	REV.	SHT.
<b>12522</b>	<b>SERIES M717 CODED</b>	<b>NC</b>	<b>15</b>

### 3.5 Electrical Performance Requirements

Electrical Life                      1,000,000 Actuations minimum.

### 3.6 Mechanical Performance

#### 3.6.1 Weight

The typical weight of a panel mount keyboard and the rear panel mounting bracket is given in Table 3.4.

Table 3.4  
**M717 Keyboard Weight**

Data Entry	Weight, Not to Exceed	
	Grams	Ounces
Panel Mount Keyboard	333	11.75
Rear Panel Mounting Bracket (5 pairs)	60	2

#### 3.6.2 Mechanical Life

Mechanical Life                      1,000,000 cycles of operation at 25 °C ambient temperature. The cycling rate is between 10 to 1000 cycles of operation per minute.

CAGE CODE:	DRAWING NO.	REV.	SHT.
<b>12522</b>	SERIES M717 CODED	NC	16

### 3.6.3 Force Travel Curve

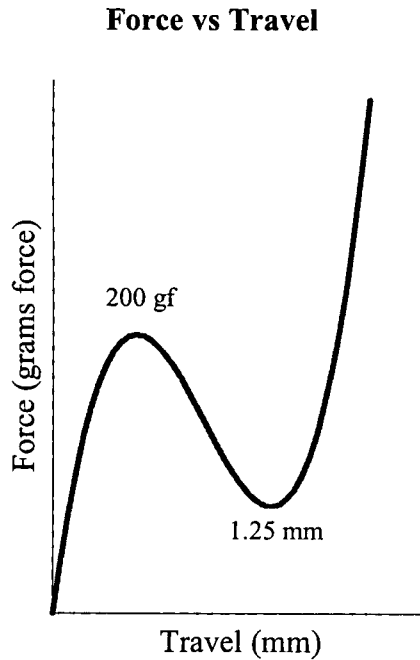

Nominal Key Travel            1.25 mm (.050 in).  
 Nominal Actuation Force    200 grams force (7.05 ounces force).

### 3.7 Environmental Requirements

The keyboard is designed to meet the following requirements.

#### 3.7.1 Temperature Range

The operating and storage temperature ranges of the panel mount keyboard shall be as shown in Tables 3.5 and 3.6.

Table 3.5  
**Unlighted Keyboard Temperature Range**

Condition	° Celsius	° Fahrenheit
Operating	-30 to 85	-22 to 185
Storage	-30 to 85	-22 to 185

CAGE CODE:	DRAWING NO.	REV.	SHT.
<b>12522</b>	<b>SERIES M717 CODED</b>	<b>NC</b>	<b>17</b>

Table 3.6  
**Lighted Keyboard Temperature Range**

Condition	° Celsius	° Fahrenheit
Operating	-25 to 65	-13 to 149
Storage	-30 to 75	-22 to 167

**3.7.2 Thermal Shock**

Thermal Shock Test: -30 °C (-22 °F) for ½ hour,  
 +75 °C (167 °F) for ½ hour  
 for 5 cycles with recovery time and temperature  
 of 5 minutes at 25 °C (77 °F).

**3.7.3 Vibration**

Vibration Test: 15 G peak or .06 inches double amplitude, 10 to 2000 Hz.

The entire frequency range of 10 to 2000 Hz and return to 10 Hz shall be traversed in 60 minutes. This cycle shall be performed once in each of three mutually perpendicular directions (total of 3 times), so that the motion shall be applied for a total period of approximately 3 hours.

**3.7.4 Shock**

Three shocks shall be applied in each direction of the three mutually perpendicular axes of the panel mount keyboard (total of 9 shocks). Each shock pulse shall have 100 G peak value, 11 ms duration, half-sine waveform and 12.3 ft/s velocity change.

**3.7.5 Moisture Resistance**

Use MIL-STD-202, method 106 as guideline to perform the moisture resistance test by setting the relative humidity between 90 and 98%, temperature cycling between 65 °C (149 °F) and 25 °C (77 °F), for 10 cycles (240 hours) and for 10 days cycling period providing that the keyboard is installed and sealed in a moisture resistance enclosure. The user is to provide installation provisions to prevent the exposure of the rear of the keyboard to moisture.

**3.7.6 NEMA 4**

Apply a continuous coat of appropriate sealing compound (GE Silicon Adhesive, RTV 108, or equivalent) between the matting surfaces of the keyboard and the panel prior to NEMA 4 test. The surface mounted panel mount keyboard shall be subjected to a stream of water from a hose that has a 25.4 mm (1 in) nozzle and delivers at least 246 liters (65 gallons) of water per minute.

CAGE CODE:	DRAWING NO.	REV.	SHT.
<b>12522</b>	SERIES M717 CODED	NC	18

The water shall be directed at all joints from all angles and from a distance of 3.05 to 3.65 meters (10 to 12 feet) for a minimum of 5 minutes providing that the keyboard is installed and sealed in a moisture resistance enclosure. NEMA 4 requirements is not applicable to rear mounted keyboards. The user is to provide installation and sealing provisions to prevent the penetration of the water to the rear of the keyboard.

### 3.7.7 Salt Spray

No functional damage will result from a test wherein the panel mount keyboard is subjected to the spray of a 5% salt and water solution at 35 °C (95 °F) for 96 hours providing that the keyboard is installed and sealed in a salt solution resistance enclosure. The user is to provide installation provisions to prevent the exposures of the rear of the keyboard to salt spray and associated contamination.

### 3.7.8 Sand and Dust

Apply a continuous coat of appropriate sealing compound (GE Silicon Adhesive, RTV 108, or equivalent) between the matting surfaces of the keyboard and the panel prior sand and dust test. The panel mount keyboard shall be exposed to three dust tests in succession. The dust shall be fine sand, and shall pass through a 140-mesh screen. The dust concentration shall be 0.3 grams (0.01 oz) per cubic foot. The dust shall be mixed with different air velocity, temperature and relative humidity as described in Table 3.7 providing that the keyboard is installed and sealed in a solid enclosure. Also specified is the duration of each test. The user to provide installation provisions to protect the rear of the keyboard against sand and dust test.

Table 3.7

**Air Characteristic and Test Duration**

Dust Test #	Velocity (ft/minute)	Temperature (°C)	Relative Humidity %	Test Duration (hours)
1	1750	23	< 22	6
2	300	63	< 10	16
3	1750	63	< 10	6

### 3.7.9 Legend Chemical Resistance

The legend shall be insecticide, glass cleaner, and hand cream resistant. Two tests shall be performed to test the legend chemical resistance.

Test one requires that the legend shall be coated with each chemical, allowed to dry, and rubbed 25 times under a load of 500 grams per square centimeter (7.1 psi).

Test two requires that the legend shall be coated with each chemical, allowed to dry, wiped away, and left for 60 hours at 60 °C (140 °F) and 95% RH.

The legend shall be readable after completion of the above tests.

CAGE CODE:	DRAWING NO.	REV.	SHT.
12522	SERIES M717 CODED	NC	19

### **3.7.10 Legend Wear**

Two tests shall be performed to test the legend wear.

Test one requires that a rubber eraser shall be dragged across the legend under a 500 gram (17.6 oz) load for 1,000 cycles at a rate of 30 cycles per minute.

Test two requires that a rubber eraser shall be dragged across the legend under a 1,000 gram (35.3 oz) load for 500 cycles at a rate of 30 cycles per minute.

The characters and symbols shall remain readable after completion of the above tests.

### **3.7.11 Legend Adhesion**

A one mm interval grid pattern shall be cut on the legend. An adhesive tape shall be applied to the surface, and rapidly peeled away.

The characters and symbols shall remain readable after completion of the above test.

### **3.7.12 Finger Print Resistance**

Two tests are required to verify the fingerprint resistance.

Test one requires that the legend shall be coated with a synthetic finger print solution, and left at 60 °C (140 °F) and 95% RH for 240 hours.

Test two requires that the legend shall be dipped in a synthetic fingerprint solution and rubbed 50 times with a cotton applicator saturated with synthetic fingerprint solution under a load of 500 grams per square centimeter (7.1 psi).

The characters and symbols shall remain readable after completion of the above tests.

## **3.8 Material Requirement**

### **3.8.1 Corrosion Resistance**

All metal parts shall be corrosion-resistant material, or shall be suitably protected to resist corrosion.

### **3.8.2 Fungus**

The panel mount keyboard shall be constructed of fungus inert materials.

CAGE CODE:	DRAWING NO.	REV.	SHT.
12522	SERIES M717 CODED	NC	20

### **3.8.3 Terminal Plating**

Printed switch board shall be plated with .00005 inches (0.0013 mm) thick 99% gold (130-200 Knoop hardness). Connector terminals (header pins) shall be gold plated 20 micro inch thick.

### **3.9 Other Requirements**

#### **3.9.1 Marking**

Data entry product package shall be legibly marked as follows:

- a) StacoSwitch name and logo (optional).
- b) StacoSwitch Manufacturer's Cage Code Identification No. 12522.
- c) StacoSwitch Part Number.
- d) Manufacturing Date Code.

#### **3.9.2 Workmanship**

Products shall be manufactured in such a manner as to be uniform in quality and free from cracked or displaced parts, sharp edges, burrs and other defects that would be detrimental to their serviceability or performance.

#### **3.9.3 Quality**

The keyboard shall be inspected and tested as necessary to substantiate product conformance to drawings and specifications. Inspection and test records shall be documented and shall be available for review.

#### **3.9.4 Changes In Specification**

Specifications defined herein are accurate at the time of release and publication of this document. StacoSwitch reserves the right to make changes without prior notice.

CAGE CODE:	DRAWING NO.	REV.	SHT.
12522	SERIES M717 CODED	NC	21

## 4.0 PART NUMBER INFORMATION

This section contains the information necessary to order each of the standard and optional features of the Series M717 panel mount keyboards described in this specification. Rear panel mounting bracket, mating connector kits, crimping tool, extraction tool, power supplies for the lighted keyboards, lighting cable, keyboard cable, and cables with ferrite beads are covered in Section 4.2.

### 4.1 M717 Panel Mount Keyboards

<div style="display: flex; justify-content: space-around; margin-bottom: 10px;"> <span>M717</span> <span>X</span> <span>X</span> <span>X</span> </div>	<p>Code</p> <p>Color            1 Black                      2 Gray</p> <p>Lighting        0 Unlighted                      1 Lighted</p> <p>Sealing         1 Sealed to NEMA 4</p> <p>Type M717      88 Key Keyboard, Panel Mount                      w/ PS/2 Encoder</p>
--	---







Table 4.1 gives the relationship between color description and Pantone number. Other colors are available by special order.

Table 4.1  
**Color Description**

Color	Pantone Number
Black	Pantone # 433 U
Gray	Pantone # Cool Gray 9 U

Typical panel mount keyboard part number is M717101. It is an 88 key panel mount PS/2 keyboard that is sealed and unlighted. The keyboard legend color is white. The keyboard color is black.

CAGE CODE:	DRAWING NO.	REV.	SHT.
<b>12522</b>	SERIES M717 CODED	NC	22

M717	1	0	1	Code	
				Color	1 Black
				Lighting	0 Unlighted
				Sealing	1 Sealed
				Type M717	88 Key Keyboard, Panel Mount w/ PS/2 Encoder

## 4.2 Accessories

### 4.2.1 Rear Panel Mounting Brackets

Rear panel mounting brackets are required for rear mounting a panel mount keyboard. Five pairs are required to rear mount a panel mount keyboard. The brackets are packaged in pairs and the part number is 15216-001.

### 4.2.2 Mating Connector Kit

For customer convenience, mating connector kits are available for the lighted and unlighted panel mount keyboards. The kits contain the number of connectors of the proper size needed to interface to the keyboard and the quantity of crimping terminals (+10%) appropriate to the configuration. Use the following table to determine the proper ordering part number.

Table 4.2  
**Kit Keypad Cross Reference**

Panel Mount Keyboard	Kit Part Number
Lighted	15229-008
Unlighted	15229-002

### 4.2.3 Crimping Tool

The crimping tool part number is 15232. The crimping tool is compatible with the terminals supplied in the 15229-002 and 15229-008 kits.

CAGE CODE:	DRAWING NO.	REV.	SHT.
<b>12522</b>	SERIES M717 CODED	NC	23

#### **4.2.4 Extractor Tool**

An extractor tool is available for use in removing crimped terminals from the connector housings used in keyboard mating connector kit. The extractor tool part number is 15233.

#### **4.2.5 Keyboard Lighting Power Supplies**

Two optional power supplies are available to light the panel mount keyboard. The power supplies convert 110 VAC to 2.1 VDC with a constant current rating of 2.65 A. Each power supply has a five-pin DIN female connector that mates with the lighting cable (part number 15240) connector. One of the power supplies is a wall mount version, while the other one is table mount version.

##### **4.2.5.1 Wall Mount Power Supply**

The part number of the wall mount power supply is 15256. The wall mount power supply plugs directly into an AC power source and provides the power output through a six foot long cord with a connector that mates with the keyboard lighting cable (part number 15240) connector. The power supply dimension is 81 x 55 x 49 mm (L x W x H) or approximately 3.2 x 2.2 x 1.9 inches. The wall mount power supply weighs approximately 306 gm (10.8 oz). The AC adapter converts 120 VAC, 47 to 63 Hz to 2.1 VDC, 2.65 A, constant current.

##### **4.2.5.2 Desktop Power Supply**

The desktop power supply part number is 15259. This power supply has two cords. One cord is approximately 2 m (6 ft) long and has a plug that plugs into an AC power source. The second cord is approximately the same length and has a five-pin male connector that mates with keyboard lighting cable (part number 15240) connector. The power supply dimension is TBD x TBD x TBD mm (L x W x H) or approximately TBD x TBD x TBD inches. The desktop power supply weighs approximately TBD gm (TBD oz).

#### **4.2.6 Keyboard Cable**

The keyboard cable, part number 15247, is a cable with a connector that mates with the panel mount keyboard connector, and a male mini six-pin PS/2 connector. The PS/2 keyboard cable allows the keyboard to be connected directly to an IBM PC PS/2 keyboard port. The cable length is about 1.8 m (5.9 ft).

CAGE CODE:	DRAWING NO.	REV.	SHT.
12522	SERIES M717 CODED	NC	24

#### **4.2.7 Lighting Cable**

The lighting cable, part number 15240, provides a standard cable connection from either the 15256 or the 15259 power supply to lighting circuits of a panel mount keyboard. The cable length is about 1.8 m (5.9 ft).

#### **4.2.8 Lighting Cable with Ferrite Bead**

The lighting cable, part number 15261, provides a standard cable connection from either the 15259 or the 15256 power supply to lighting circuits of a panel mount keyboard. The cable has a ferrite bead near the keyboard connector end. The ferrite bead reduces interference and improves the reliability of the keyboard. The cable length is about 1.8 m (5.9 ft).

#### **4.2.9 Keyboard Cable with Ferrite Beads**

The keyboard cable, part number 15262, is a cable with a connector that mates with the panel mount keyboard connector, and a male mini six-pin PS/2 connector. The PS/2 keyboard cable allows the keyboard to be connected directly to an IBM PC PS/2 keyboard port. The cable has a ferrite bead near each end of the cable. The ferrite beads reduce interference and improve the reliability of the keyboard. The cable length is about 1.8 m (5.9 ft).

#### **4.2.10 PC/AT Keyboard Adapter**

The PC/AT keyboard adapter part number is 15260. It facilitates the panel mount keyboard with its keyboard cable to be connected directly to an IBM PC/AT standard 5-pin DIN keyboard connector. The PS/2 side of the adapter is female, and the AT side is male. The PC/AT keyboard adapter weighs approximately 18.5 gm (0.66 oz). The adapter diameter is about 20.3 mm (.80 in) and the length is about 56 mm (2.20 in).

CAGE CODE:	DRAWING NO.	REV.	SHT.
12522	SERIES M717 CODED	NC	25