

PHONE: (714)549-3041 FAX: (714)549-0930 © Copyright StacoSwitch Inc., 2003	 1139 BAKER ST. COSTA MESA, CA. 92626 A Components Corporation of America Company		NAME	DATE
		ORIGINATOR	A. KERTATAMA	14AP03
		APPROVED	<i>[Signature]</i>	4-15-03
	CAGE CODE: 12522	APPROVED	<i>[Signature]</i>	4-15-2003

**Part of the M7 Family of
MET Data Entry Products**

M725/0001

PC-COMPATIBLE TRACKBALL
In Metal Enclosure

THREE BUTTON MILITARY USB TRACKBALL

M725/0001-SCD

The Information and design disclosed herein was originated by and is the property of STACOSWITCH, INC. STACOSWITCH, INC. reserves all patent, proprietary, design, manufacturing, reproduction, use and sale rights thereto, and to any article disclosed therein, except to the extent fights are expressly granted to others. The foregoing does not apply to vendor proprietary parts.

M725/0001-SCD A

SHEET 1 OF 13

TABLE OF CONTENTS

1.0 SCOPE.....	4
1.1 DESCRIPTION.....	4
1.2 SPECIAL FEATURES.....	4
2.0 PC-COMPATIBLE TRACKBALL.....	5
2.1 PRODUCT FEATURES.....	5
2.2 TRACKBALL IN METAL ENCLOSURE	5
2.3 COLOR	6
2.4 WATERPROOF ENCLOSURE ASSEMBLY	6
2.5 DRAIN PIPE	6
2.6 BACKLIGHTING.....	6
3.0 REQUIREMENTS.....	7
3.1 DIMENSIONS.....	7
3.2 TRACKBALL MOUNTING.....	8
3.3 INTERFACE CONNECTION	9
3.4 PUSH BUTTON ELECTRICAL PERFORMANCE REQUIREMENTS.....	9
3.5 MECHANICAL PERFORMANCE	10
3.5.1 Trackball Assembly Weight.....	10
3.5.2 Push Button Mechanical Life	10
3.5.3 Push Button Force Travel Curve.....	10
3.6 ENVIRONMENTAL REQUIREMENTS	11
3.6.1 Temperature Range.....	11
3.6.2 Vibration	11
3.6.3 Shock	11
3.6.4 Humidity.....	11
3.6.5 R. F.	11
3.6.6 Altitude	12
3.6.7 MTBF	12
3.7 MATERIAL REQUIREMENT.....	12
3.7.1 Corrosion Resistance	12
3.7.2 Fungus.....	12
3.7.3 Finish.....	12
3.8 OTHER REQUIREMENTS.....	13
3.8.1 Marking.....	13
3.8.2 Workmanship.....	13
3.8.3 Quality.....	13
3.8.4 Changes in Specification	13

CAGE CODE:	DRAWING NO.	REV.	SHT.
12522	M725/0001-SCD	A	3

PRODUCT SPECIFICATION
M725/0001
PC-COMPATIBLE TRACKBALL
In Metal Enclosure

1.0 SCOPE

This Specification Control Document (SCD) describes the detailed characteristics of one of the M7 Family of data entry devices using Molded Elastomer Technology (MET). The product emanating from this SCD is designated as M725/0001.

1.1 Description

The M725/0001 PC-Compatible trackball includes a 2" diameter ball and a three button keypad, installed in a metal enclosure. The trackball is equivalent to a three button mouse. The trackball interfaces through a MIL-C-38999 connector, and it is USB compatible. The trackball is designed to meet USB Specification 1.1 using the designated USB cable per Specification 1.1

1.2 Special Features

The trackball is designed with shielding, noise suppression diodes and specially designed printed circuit board to minimize EMI/RFI and provide High Amplitude Electromagnetic Pulse protection. The printed circuit board has four layers and each layer performs a different function for EMC/RFI considerations. The top and bottom layers have continuous copper etch shields that are tied together to the cable shields to intercept internal and external RFI signals.

The trackball is also incorporated with the appropriate design measures to withstand the requirements of the environment tests described in paragraph 3.6 of this SCD.

CAGE CODE:	DRAWING NO.	REV.	SHT.
12522	M725/0001-SCD	A	4

2.0 PC-COMPATIBLE TRACKBALL

2.1 Product Features

The PC-Compatible trackball is designed to be rugged and durable, yet provide modern styling. It is compatible with Windows 98 and 2000 operating systems.

2.2 Trackball in Metal Enclosure

The trackball is designed in a metal enclosure as shown in Figure 2.1. The trackball has a built-in encoder with USB interface and noise suppression devices to minimize EMI and provide HAEMP protection. The trackball has plastic keycaps. The trackball is a plug and play device.

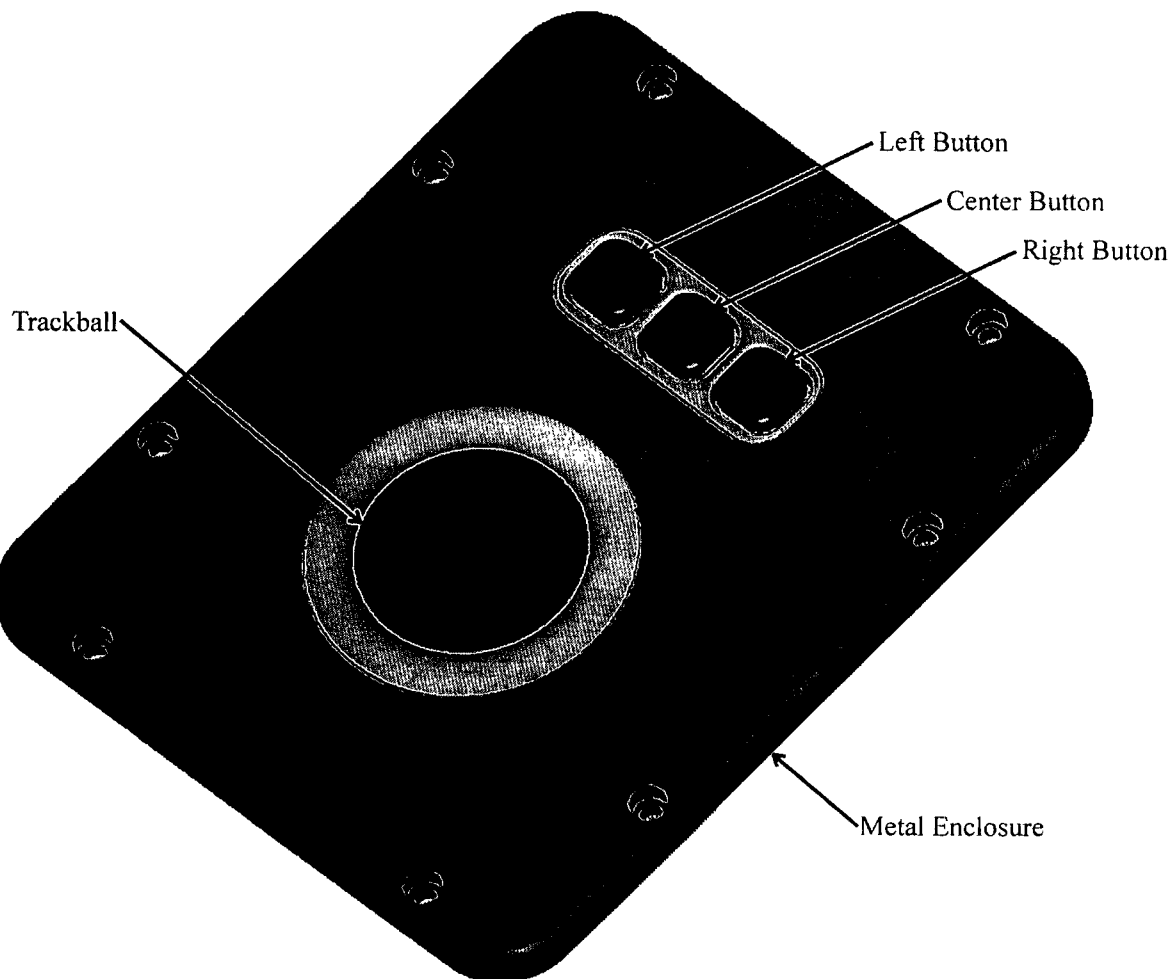

Figure 2.1
Trackball

CAGE CODE:	DRAWING NO.	REV.	SHT.
12522	M725/0001-SCD	A	5

The trackball has three buttons similar to that of a mouse. It's left, right and center buttons perform similar functions of a typical mouse with similar applicable platforms.

2.3 Color

The trackball is colored black, and the three button keys are colored gray.

2.4 Waterproof Enclosure Assembly

The trackball is designed to be waterproof. There is a breather vent installed on the side of the unit for equalizing the air pressure inside the sealed unit to that of the surrounding atmosphere. It is required to clean the breather vent periodically with soft tooth brush and clean water. The breather vent is not waterproof.

2.5 Drain Pipe

The trackball is facilitated with a drain pipe allowing to discharge water or condensation collected within the gap of the ball and the cup assembly. The user may incorporate an EMI/EMC shielding to the extension of the drain pipe to minimize EMI/EMC effects.

2.6 Backlighting

The trackball pushbuttons are not furnished with backlighting. The backlighting feature is optional.

CAGE CODE:	DRAWING NO.	REV.	SHT.
12522	M725/0001-SCD	A	6

3.0 REQUIREMENTS

This specification defines the detailed requirements for the M725/0001 trackball. For all tests specified in this document, the test sample shall be mounted in such a manner as to simulate in-service use unless the specific test method precludes such mounting.

3.1 Dimensions

The trackball outline dimensions are shown in Figure 3.1.

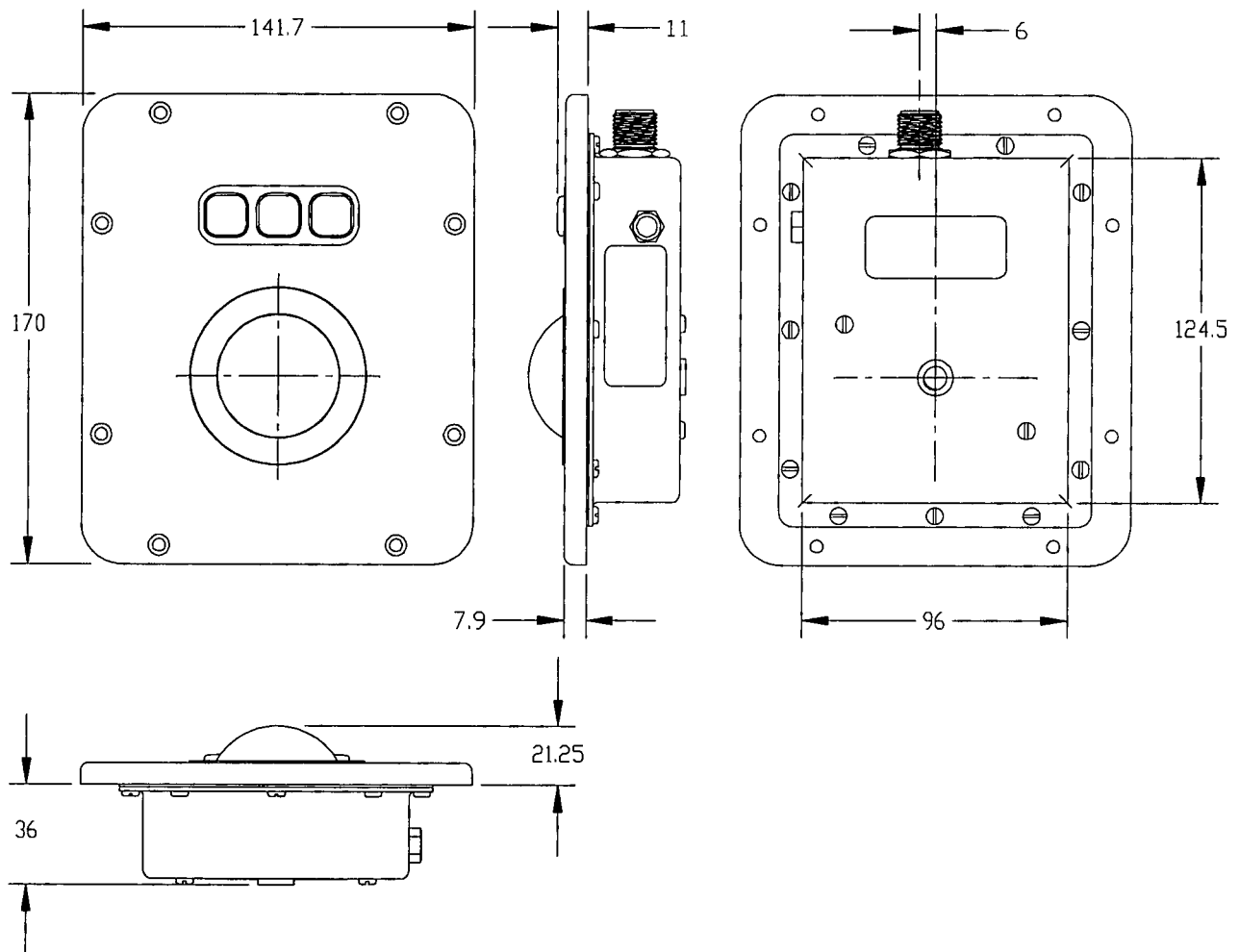

DIMENSIONS ARE IN MILLIMETERS

Figure 3.1
Trackball Outline Dimensions

CAGE CODE:	DRAWING NO.	REV.	SHT.
12522	M725/0001-SCD	A	7

3.2 Trackball Mounting

The trackball is designed for surface mount application. Figure 3.2 shows the panel cutout and hardware recommendation for surface mounting a trackball. The trackball has a drain (tapped 1/8 in pipe) to permit any liquid that may enter the ball cavity to be removed.

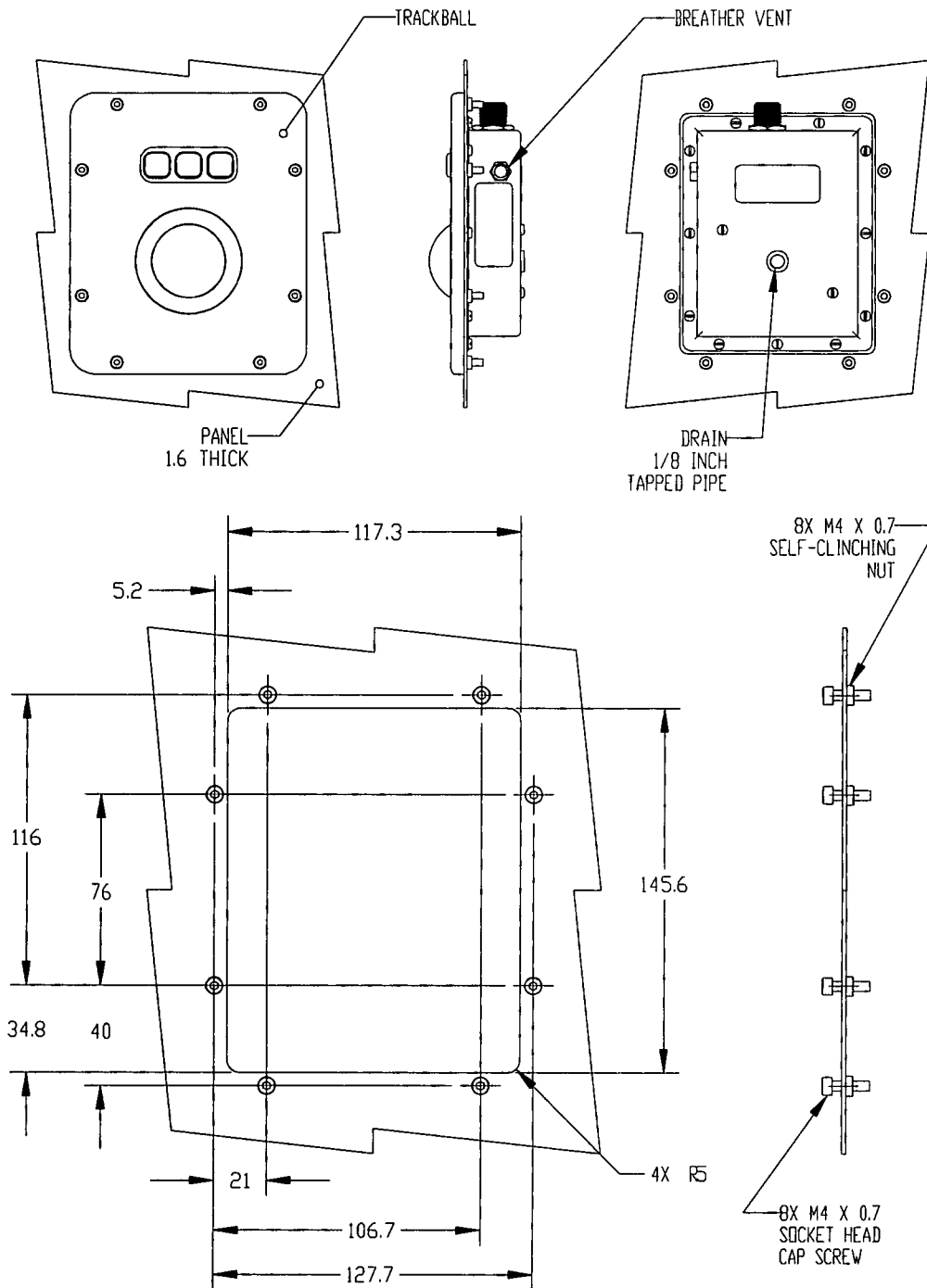

DIMENSIONS ARE IN MILLIMETERS.

Figure 3.2

Panel Cutout and Hardware Recommendation for Surface Mounting a Trackball

CAGE CODE:	DRAWING NO.	REV.	SHT.
12522	M725/0001-SCD	A	8

The recommended mounting torque to be applied to the mounting screws is to be determined by the specific customer application and in compliance with the required effective EMI shield and the mounting panel thickness.

3.3 Interface Connection

The trackball can be directly connected to a host computer or to a host keyboard (PN: M756/0003). The connection to the host keyboard (PN: M756/0003) or the host computer is identical. The connection is through a MIL-C-38999 Series III connector. A cable with a mating military connector could provide interface per USB 1.1 specification. MIL-C-38999 Series III jam nut receptacle, PN: D38999 24WA35PA, is used to interface with the host keyboard or the host computer. Figure 3.3 shows the pin numbers of the receptacle, and Table 3.1 shows the description of each pin. Power requirement for the trackball is 5 VDC @ 100mA, and it is supplied either by the host computer or the keyboard hub.

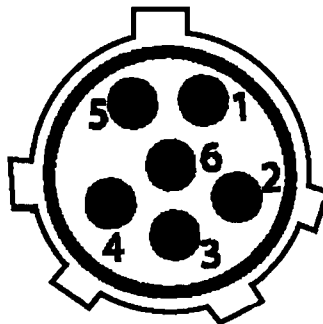

Figure 3.3
Trackball Receptacle Pin Number

Table 3.1
Trackball Receptacle Pin Number and Description

Pin Number	Description
1	Universal Serial Bus, USB +5 VDC
2	Universal Serial Bus, USB GND
3	Universal Serial Bus, USB D+
4	Universal Serial Bus, USB D-

3.4 Push Button Electrical Performance Requirements

Electrical Life 1,000,000 Actuations minimum at rated load.

CAGE CODE:	DRAWING NO.	REV.	SHT.
12522	M725/0001-SCD	A	9

3.5 Mechanical Performance

3.5.1 Trackball Assembly Weight

The typical weight of the trackball is given in Table 3.2.

Table 3.2
M725/0001 Trackball Weight

Data Entry	Weight, Not to Exceed	
	Kilograms	Lbs
Trackball	1	2.2

3.5.2 Push Button Mechanical Life

Mechanical Life 1,000,000 cycles of operation at 25 °C ambient temperature. The cycling rate is between 10 to 1000 cycles of operation per minute.

3.5.3 Push Button Force Travel Curve

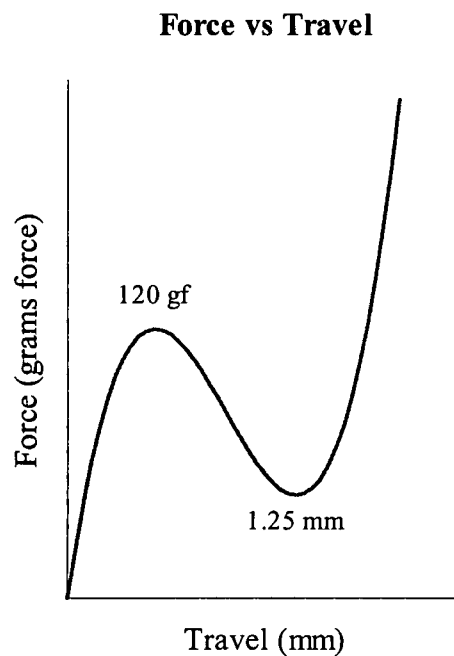

Nominal Key Travel 1.25 mm (.050 in).
Nominal Actuation Force 120 grams force (4.23 ounces force).

CAGE CODE:	DRAWING NO.	REV.	SHT.
12522	M725/0001-SCD	A	10

3.6 Environmental Requirements

The trackball is designed to meet the following environmental conditions.

3.6.1 Temperature Range

The operating and storage temperature ranges of the trackball shall be as shown in Table 3.3.

Table 3.3
Trackball Temperature Range

Condition	° Celsius
Operating	0 to 50
Storage	-40 to 85

3.6.2 Vibration

Sinusoidal Vibration: 5 G, 10 Hz to 2000 Hz.

3.6.3 Shock

Shock: 20 G any axis with one fourth of Cosine waveform and duration of 5 ms.

3.6.4 Humidity

Humidity: 95% Relative Humidity (non-condensing operational) at 50 °C.

3.6.5 R. F.

FCC Part 15 Subpart 3 requires the trackball to be tested with a host computer.

CAGE CODE:	DRAWING NO.	REV.	SHT.
12522	M725/0001-SCD	A	11

3.6.6 Altitude

Altitude: 50,000 ft operational

3.6.7 MTBF

MTBF: 25,000 Hours

3.7 Material Requirement

3.7.1 Corrosion Resistance

All metal parts shall be designed to corrosion-resistant material requirements, or shall be suitably protected to resist corrosion.

3.7.2 Fungus

The trackball shall be constructed of fungus inert materials. This requirement shall be demonstrated by analysis and design.

3.7.3 Finish

The trackball is made of materials which have been chosen for good chemical resistance. The enclosure has black paint on non-conductive surfaces and chemical film coating on conductive surfaces.

CAGE CODE:	DRAWING NO.	REV.	SHT.
12522	M725/0001-SCD	A	12

3.8 Other Requirements

3.8.1 Marking

Data entry product package shall be legibly marked as follows:

- a) StacoSwitch name and (optional) logo.
- b) StacoSwitch Manufacturer's Cage Code Identification No. 12522.
- c) StacoSwitch Part Number.
- d) Manufacturing Date Code.
- e) Serial Number.
- f) Breather Vent.

3.8.2 Workmanship

Trackball shall be manufactured in such a manner as to be uniform in quality and free from cracked or displaced parts, sharp edges, burrs, flaws and other defects that would be detrimental to their serviceability, usage or performance.

3.8.3 Quality

The trackball shall be inspected and tested as necessary to substantiate product conformance to drawings and specifications. Inspection and test records shall be documented and shall be available for review.

3.8.4 Changes in Specification

Specifications defined herein are accurate at the time of release and publication of this document. StacoSwitch reserves the right to make changes without prior notice.

CAGE CODE:	DRAWING NO.	REV.	SHT.
12522	M725/0001-SCD	A	13