

Lighted Pushbutton Switches

Series 50 Dripproof Display

STACO SWITCH

A Components Corporation of America Company

Models 5M, 5SM, 505M
Matrix Systems
Models 59, 59C Individual
Mount Switches and Indicators
Model 52 Individual
Mount Indicators

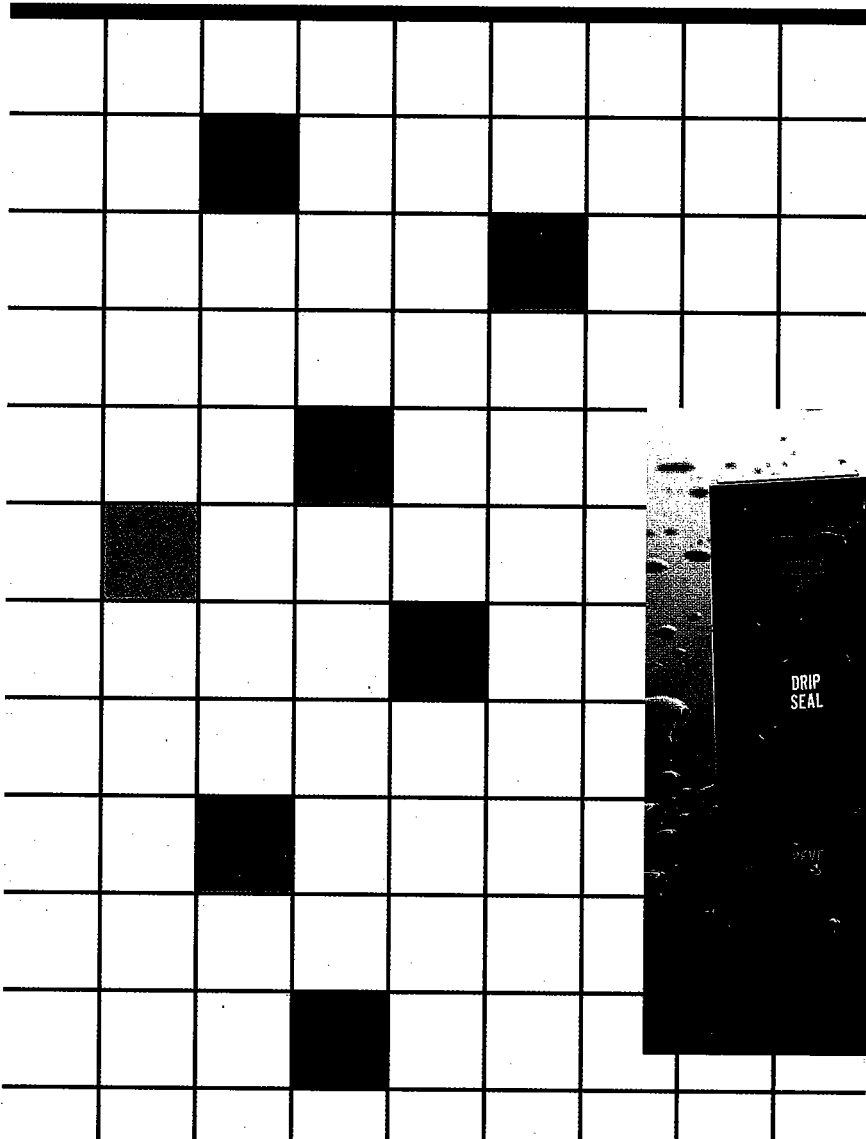



NEW DRIPPROOF DESIGN

Stacoswitch's new Series 50 Dripproof Sealed Lighted Display Pushbutton Switch/Indicators are designed for those problem switch installations that may be exposed to rain, open deck spray, condensation on panel surfaces, or similar applications in which moisture may be encountered. The display pushbutton's captive rubber seal, precisely seated in the switch body, effectively closes all possible paths that moisture might follow into the switch. A rubber gasket seals the face plate to the pushbutton body.

The design of the captive rubber seal on the pushbutton body allows unrestricted movement of the pushbutton for switch actuation. There is no increase in operating force because of the rubber seal. Nor does the rubber seal hamper the front release feature of Stacoswitch's latch lever design allowing relamping of the pushbutton from the front of the panel without use of tools.

All Series 50 Dripproof Sealed Lighted Display Pushbutton Switch/Indicators meet or exceed the requirements of MIL-STD-108E of MIL-S-22885. The sealed switches are designed to withstand drops of water falling vertically, at a rate of five gallons in a five minute duration, on a panel inclined 15 degrees. The Switch and pushbutton will continue to operate with no evidence of accumulation of water within the switch enclosure, and with no harmful effect on switch operation.

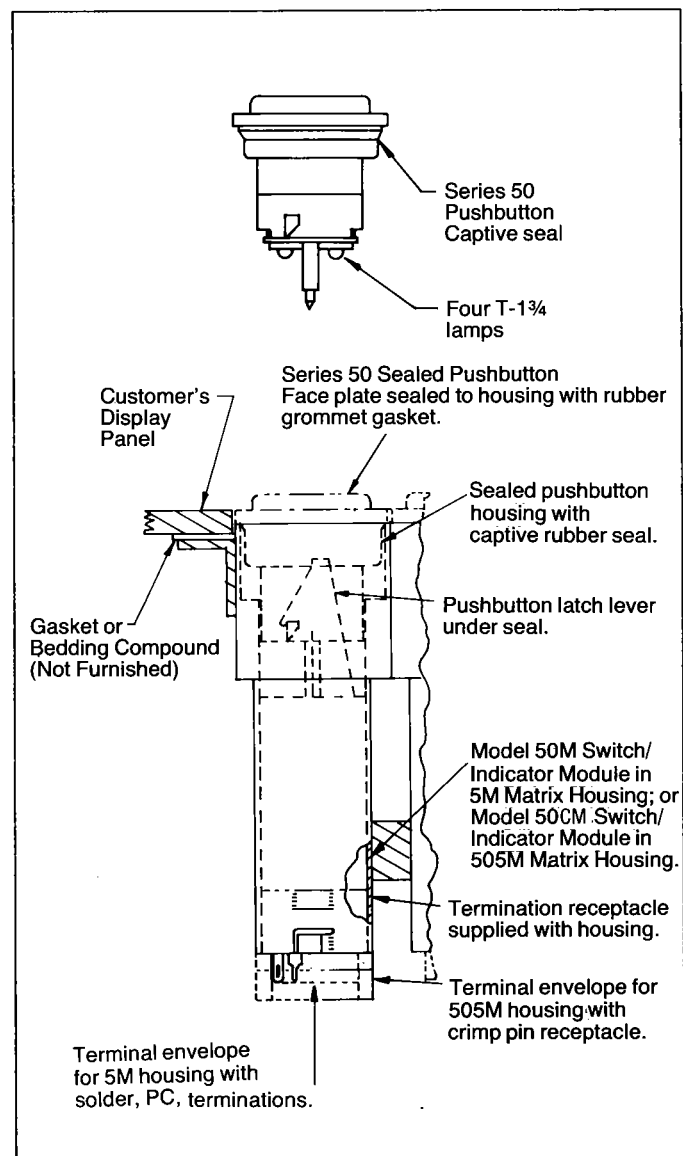

General Information

The catalog has been structured to simplify as much as possible locating information required for the selection of the proper switch or indicator and display pushbutton, and for determining the part number or numbers for ordering complete assemblies. Step-by-step procedures for determining part numbers are given for each standard product in the catalog.

Engineering Data

Page 4

Series 5M, 505M, and 5SM Matrix Systems

To order a complete Matrix System it is necessary to order the matrix housing, switch-indicator modules, and display pushbuttons separately, specifying a part number for each. Once your description of components is determined, including a part number for each, the complete assembly can be ordered as a unit, if desired. Contact factory for assembly part number. Lamps must be ordered separately, specifying required voltage and M.S.C.P.

Series 5M, 505M, 5SM Housings
Series 50M, 50CM, 50SM Modules
Series 50 Display Pushbuttons
Lamps and Accessories

Pages 5-10
Pages 11-14
Pages 15-18
Page 23

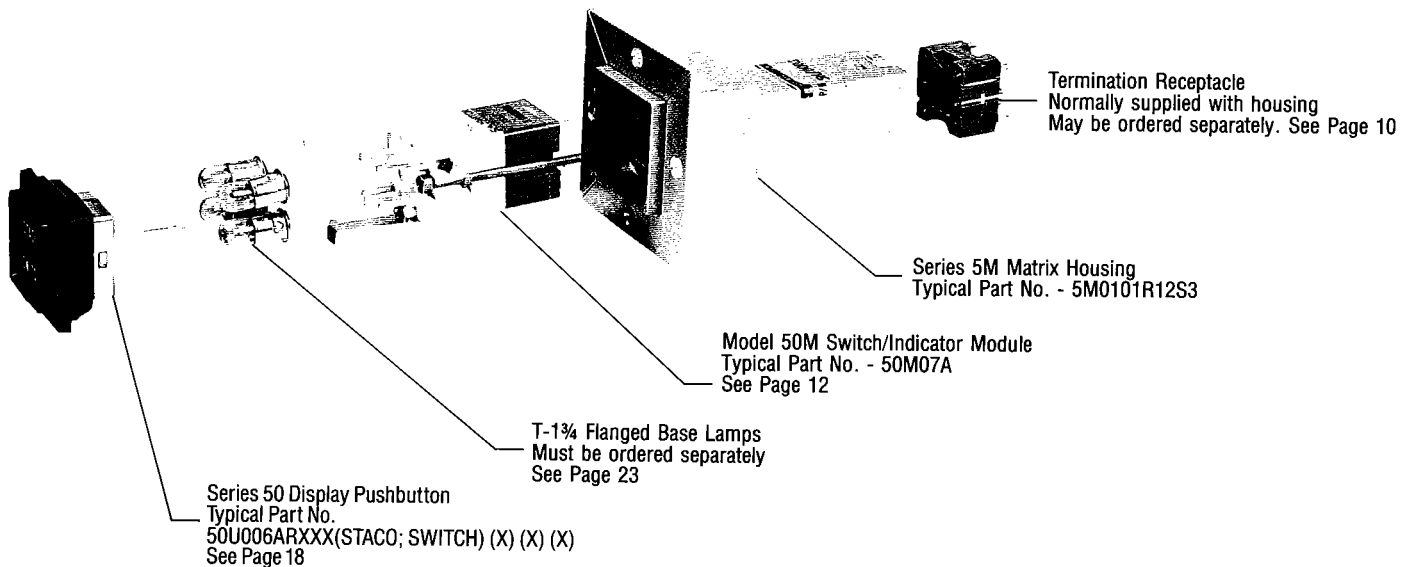

See Page 10 for information on ordering complete assembly...pushbutton, switch/indicator module, and housing...under one assembly part number.

Model 59 and 59C Individual Mount Switch/Indicators Model 52 Individual Mount Indicator

To order a complete switch and pushbutton assembly or indicator and pushbutton assembly, it is necessary to order each component separately, specifying a part number for each. Once your description of parts is determined, including a part number for each, the complete switch/pushbutton assembly can be ordered as a unit if desired. Contact factory for assembly part numbers. Lamps must be ordered separately, specifying voltage and M.S.C.P. required.

Model 59 Switch/Indicator
Model 59C Switch/Indicator
Model 52 Indicator Only
Model 50 Display Pushbuttons
Lamps and Accessories

Pages 19 & 20
Pages 19 & 21
Pages 19 & 22
Pages 15-18
Page 23

PRODUCT DESIGN AND ENGINEERING DATA

GENERAL INFORMATION — Stacoswitch products are designed and manufactured to meet exacting specifications of Original Equipment Manufacturers who demand dependability, attractive appearance, and maximum value from their products. Combining imaginative engineering with manufacturing know-how Stacoswitch offers the most versatile and reliable circuit control components available.

Stacoswitch's full line of Lighted Pushbutton Switches and Indicators provide a wide selection of circuitry control capabilities and display screen combinations. It costs no more to specify the very finest. Design and performance features, durability, cost savings and realistic delivery schedules all combine to make Stacoswitches your best buy. When you compare total cost . . . purchase, installation, and maintenance . . . you can't beat Stacoswitch.

QUALITY CONTROL — Stacoswitch, as a part of its operation, maintains a Quality Control Department which encompasses all of the functions required to attain the company's high quality objectives in every level of production, as well as requirements of the most discriminating customers. The inspection system and documentation used to control the quality of products manufactured conforms to all requirements of MIL-I-45208A. As an approved manufacturer of Qualified Products List (QPL) parts Stacoswitch's program is regularly monitored by the appropriate Defense Department Agencies.

QUALIFIED PARTS LISTINGS—Various Stacoswitch switches and indicators, including Series 1M, 40 and 60, have been granted Qualified Products Listing under MIL-S-22885, MIL-S-24317, or MIL-S-8805. These same products have been seismic qualified to the requirements of I.E.E.E. Standard 323-1974, 344-1975, and 381-1977. All Stacoswitch switches are manufactured to meet or exceed the military requirements for thermal shock, shock, vibration, high impact shock, sand and dust, humidity, salt spray, explosion proof, temperature, altitude, and fungus resistance, as well as the shock and vibration requirements for seismic qualified applications.

In addition, Stacoswitch's new Series 5M, 5SM, 505M Matrix Lighted Display Switch/Indicator Systems, and Model 59 and 59C Switches, and Model 52 indicator meet the requirements of MIL-STD-108E of MIL-S-22885 which defines and establishes the requirements for dripproof electrical and electronic equipment. The rubber seal on these switch and indicator display pushbuttons is designed so that drops of water falling on the face of the panel, at a rate of five gallons in a five minute duration, will have no harmful effect on switch or indicator operation.

MATERIALS—Plastic body of the basic switch/indicator module is made of a premium grade glass filled thermoplastic polyester. This material offers high impact strength, dielectric strength, and insulation resistance. U.L. recognized, the plastic is fire resistant and flame retardant. Though resistant to many common solvents and cleaning solutions it is recommended that isopropyl alcohol is used for cleaning.

Switch housings are made of aluminum for high structural strength and light weight. Black anodized finish on non-shielded switch/indicators provide corrosion resistant surface. RFI/EMI shielded units have conductive chem-film, irridite finish that is equally corrosion resistant. Commercial grade switch/indicators have clear aluminum housings.

Contact materials are high conductivity precious metal alloys, gold plated. Switch moving contacts are not based on over-center springs. No springs are used as conductors, eliminating all problems of annealing and loss of spring pressure.

Pushbutton plastic color chips provide controlled color diffusion and excellent resistance to high temperature. Face plate has high structural strength and hardness to resist surface scratches. Pushbutton assembly provides structural strength and heat sinking capability.

HEAT—Materials used in Stacoswitch units provide excellent resistance to high temperatures. For comfort of human interface the switch can be operated in most conditions with up to two lamps continuous duty. In matrix assemblies where significant temperature potential exists external cooling or heat sinking may be required to maintain comfortable pushbutton surface temperature. Reduced build-up of heat where continuous lamp duty is required can be achieved by dispersing these switch or indicator stations throughout the matrix rather than

grouping them in one area of the assembly. Specific units can be designed with heat rise as a specific consideration, though at the expense of other factors. Contact factory for design assistance.

LIGHTING—Stacoswitch maintains a fully equipped and certified light laboratory. Tests are performed in compliance with National Bureau of Standards and military specifications, including MIL-S-22885, MIL-C-25050, MIL-L-25467, MIL-P-7788D, and Fed STD. No. 3. Among the light laboratory capabilities are brightness, color, contrast, reflectance, angle of observation, high intensity (sunlight readability and contrast), and LED measurement. All measurements and equipment calibrations are traceable to the National Bureau of Standards.

Stacoswitch units accept T-1- $\frac{3}{4}$ midget flange base incandescent lamps, M25237 or equivalent, with design voltage ranging from 1.35 to 28 VDC, and neon lamps for operation on 115VAC. Pushbutton temperature is directly related to brightness and power consumption of the lamps selected to provide the required color and brightness. A reduction of temperature can be achieved by reducing the power consumed by the lamp, if lower brightness is acceptable. Within the parameters of the selected lamp, display colors, and legend style, color and brightness within a customer specified range can be furnished.

LOADS—Switch load ratings are a function of a number of variables. Life, temperature, duty cycle, and type of load, whether resistive or inductive, are among the considerations. Catalog ratings are intended as an optimum rating, considering all factors. All catalog ratings include a safety margin of 150% of rated loads under prescribed conditions. Switches are capable of switching an open circuit load of 10 times the rated resistive.

The basic switch module used in all Stacoswitch 4-lamp switches is a U.L. recognized component listed under File No. E50237. It is impossible to supply U.L. Listings under all possible configurations. Contact factory for assistance on specific listing requirements.

For evaluation of contact ratings refer to the following chart showing life/load switching capacities:

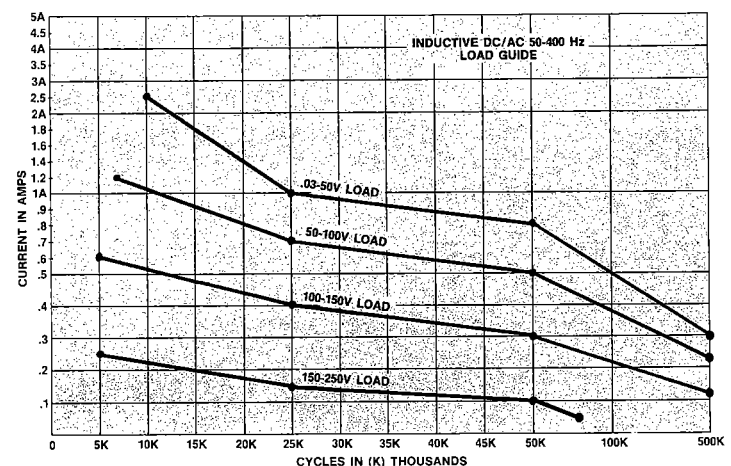
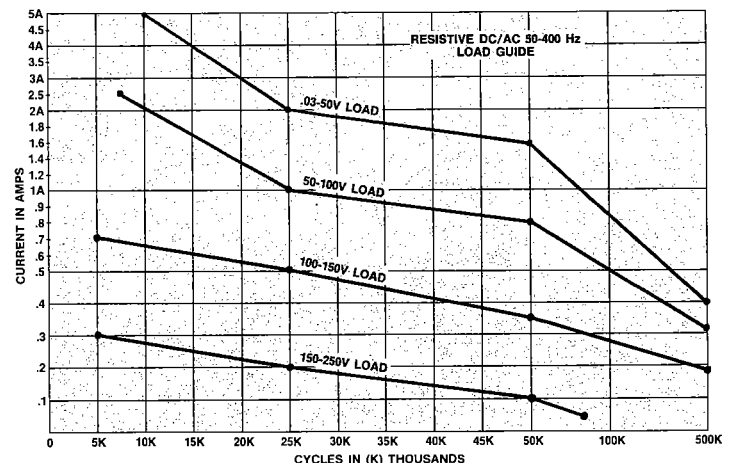

SERIES 5M, 5SM, AND 505M MATRIX SYSTEM HOUSINGS

Series 5M and 505M Matrix Switch/Indicator Systems are complete multi-station assemblies enclosed in a single, integrated housing. Custom assembled to specified configuration, the housings may have anywhere from one to one hundred or more switch and indicator stations. Similarly, the 5SM Short Matrix Indicator provides a complete annunciator system in a compact package requiring a minimum amount of length behind the panel.

RUGGED CONSTRUCTION—Housing assembly is a modular unit custom assembled to desired number of stations. Constructed of sturdy square aluminum tubes, the lightweight, yet rugged housing actually strengthens the panel, regardless of cutout size.

CHOICE OF MOUNTING STYLES—Matrix housings are available with rear mount slotted-hole flanges, or with front mount dress bezel. Rear mount flanges on all four sides of the housing have custom set-back to allow for specified panel thickness. Housing and flanges are available with black anodized finish or with RFI/EMI shielded irridite coating. Front mount dress bezels, available in clear, black anodize, RFI/EMI coating, or special order color, allows the housing assembly to be inserted through the panel opening from the front of the panel. Mounting cleats, inserted from the rear of the panel, are tightened against the panel, securely fastening the entire assembly in place. In addition to greatly simplifying installation, the dress bezel lends a very attractive appearance that is compatible with the most modern machine design.

SERIES 5M WITH CHOICE OF PC OR SOLDER TERMINATIONS—Accepts the $\frac{3}{4}$ " square Model 50M Switch/Indicator Modules and the Series 50 Dripproof Lighted Display Pushbutton. The plug-in modules are available in 2PDT and 4PDT circuitry with either common or split lamp grounds, and with momentary, alternate, and solenoid held switch actions, or as an indicator only with either common or split lamps grounds. The modules can be replaced from the front of the panel without touching the behind-the-panel wiring. Jackscrews facilitate insertion and removal of the modules. PC board and solder terminations are standard options. Termination receptacles are supplied with the matrix housing and are installed at the rear of each switch or indicator station. Pushbuttons can be easily removed from the front of panel for relamping without the use of special tools.

SERIES 505M WITH CRIMP PIN TERMINATIONS—Accepts the $\frac{3}{4}$ " square Model 50CM Switch/Indicator Modules and the Series 50 Dripproof Lighted Display Pushbutton. Plug-in modules are available with 2PDT and 4PDT circuitry with either common or split lamp grounds, and with momentary or alternate switch action, or as an indicator only with either common or split lamp grounds. Jackscrews facilitate insertion and removal of the modules from front of the panel. There's no need to touch behind-the-panel wiring. Pushbuttons can also be easily removed from front of the panel for relamping without special tools. Termination receptacles accept male crimp pin connectors on #20, #22, or #24 wire. Mating retainer holes in termination receptacles and female connectors in switch/indicator modules securely hold crimp pin connectors with a retention force of 20 pounds. Termination receptacles are installed at rear of each switch or indicator station in the matrix housing.

SERIES 5SM INDICATOR ONLY SHORT MATRIX HOUSING—This compact dripproof assembly extends only 1.45" behind the front of the panel. Custom assembled to required number of stations, these "space-savers" group all status indicators in one convenient area. Model 50SM Indicator Modules and Series 50 Dripproof Lighted Display Pushbuttons are used with the Series 5SM Matrix Housing.

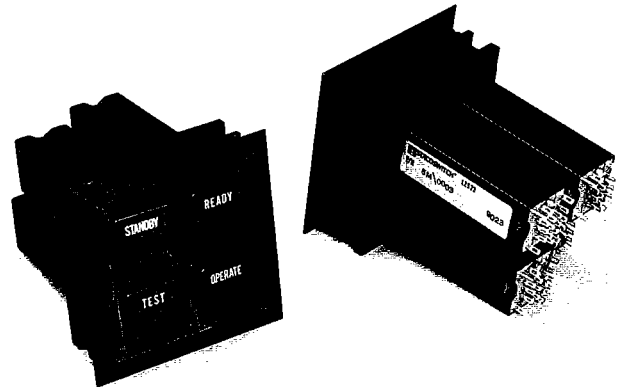

Series 5M Dress Bezel Housing with modules and pushbuttons installed. Unit shown has three "D" solenoid-held switches and one "A" switch. See note at bottom of page 9 Ordering Information when specifying system with "D" and "A", "B", or "I" modules and/or common and split lamp grounds.

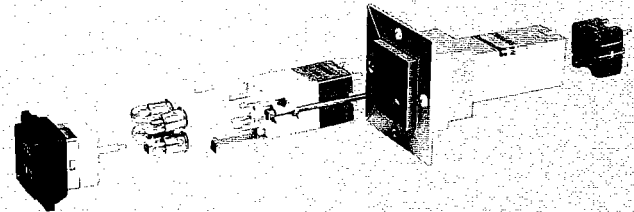

Components comprising a complete matrix system are displayed here with a single station Series 5M Housing and Receptacle. Pushbutton, lamps, switch/indicator module, and housing must be ordered separately. See page 10 for information on ordering systems with factory assigned assembly number.

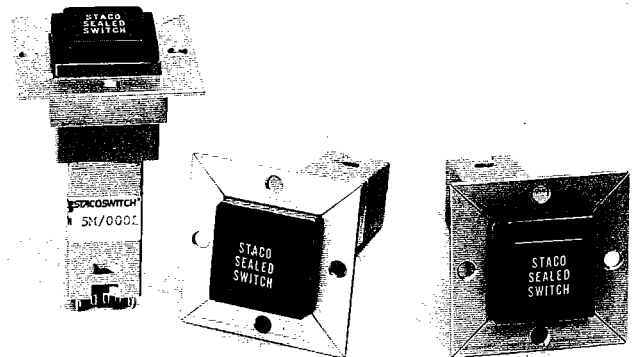

Single station, rear mount housing, Series 505M Crimp Pin Terminal Matrix, right and center; and a Series 5M Matrix with solder termination receptacle, left. Units have dripproof pushbuttons installed.

MATRIX HOUSING DIMENSIONS

Series 5M, 505M, and 5SM with rear mount flange

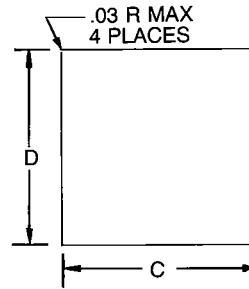
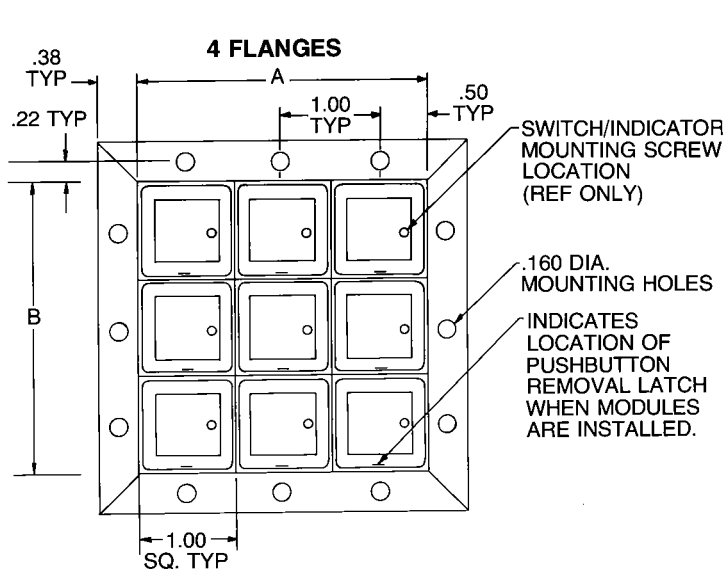

RECOMMENDED PANEL MOUNTING DETAIL

NUMBER OF UNITS ON SIDE	MATRIX DIMENSION A OR B ±.015	CUT-OUT DIMENSION C OR D +.03 -.00
1	1.000	1.010
2	2.000	2.010
3	3.000	3.010
4	4.000	4.010
5	5.000	5.010
6	6.000	6.010
N	1.000 X N	1.000 X N +.010

Series 5M, 505M, and 5SM with front mount dress bezel

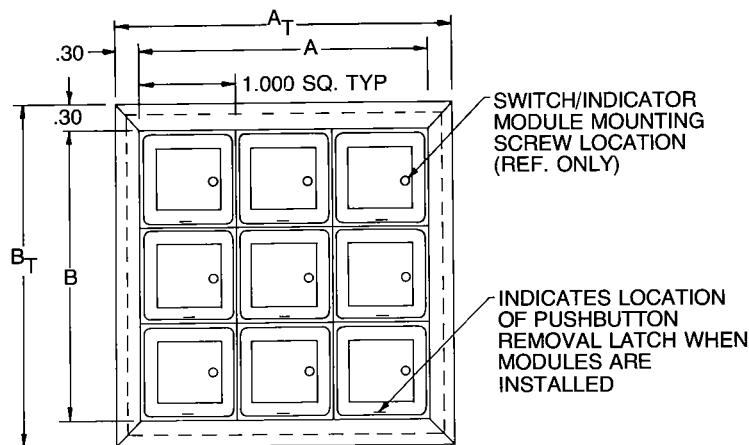

NUMBER OF UNITS PER SIDE	MATRIX DIMENSION "A" OR "B" ±.015	CUT-OUT "C" OR "D" +.030 -.000	"A _T " OR "B _T " REF OVERALL FLANGE
1	1.000	1.320	1.600
2	2.000	2.320	2.600
3	3.000	3.320	3.600
4	4.000	4.320	4.600
5	5.000	5.320	5.600
6	6.000	6.320	6.600
"N"	1.000 X N	DIM A OR B PLUS .320	DIM "A" OR "B" PLUS .600

RECOMMENDED PANEL CUTOUT FOR BEZEL MTG.

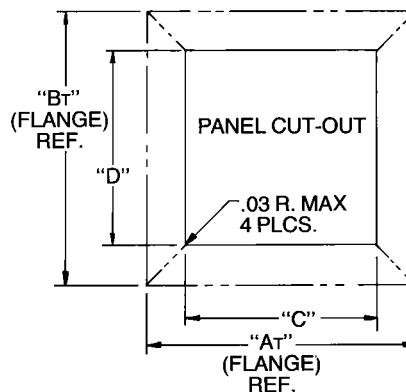

RECOMMENDED PANEL MOUNTING DETAIL

MATRIX HOUSING DIMENSIONS

Series 5M Housing

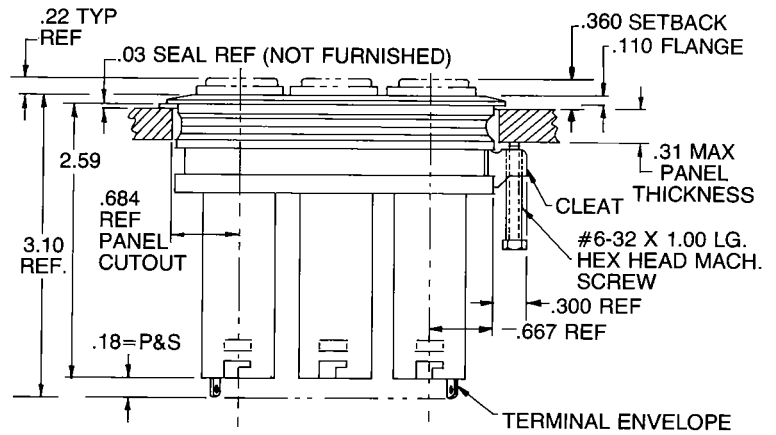
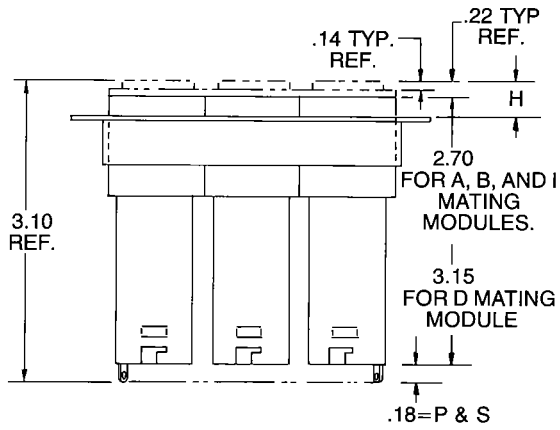

H=Flange Setback 0.28 min, 0.78 max

Series 505M Housing

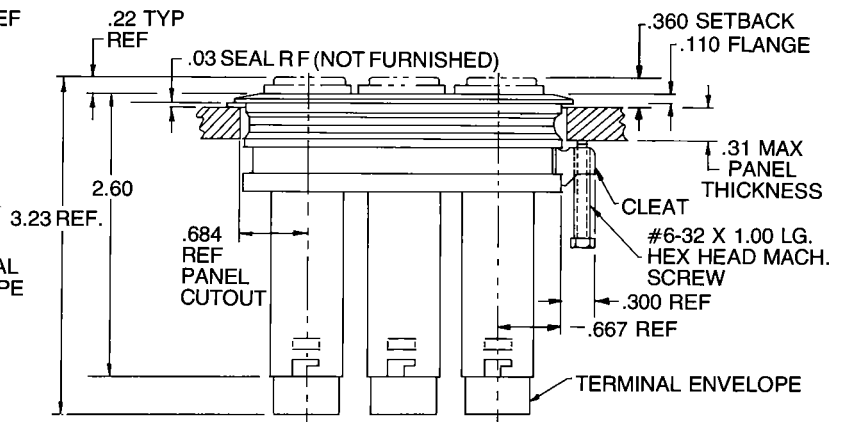
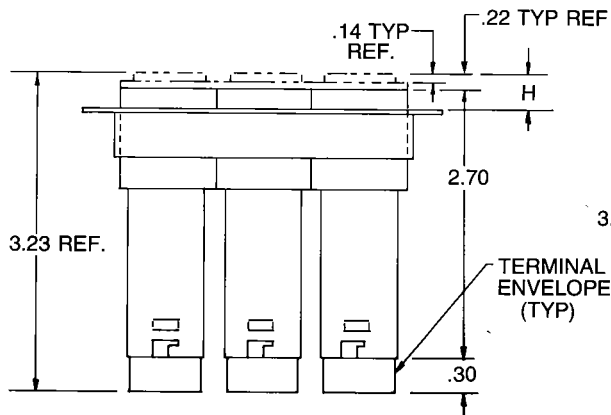

H=Flange Setback 0.28 min, 0.78 max

Series 5SM Housing

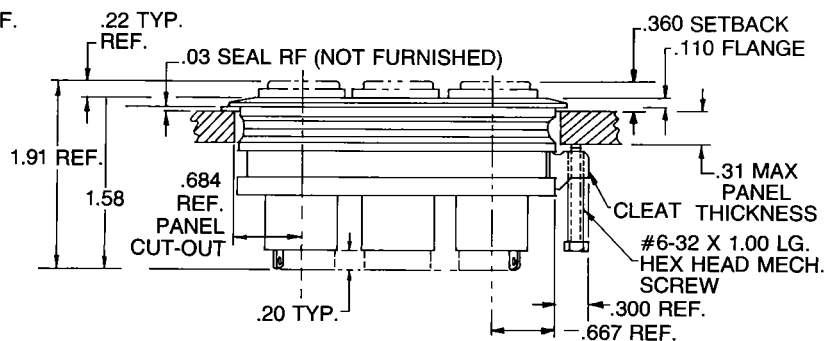
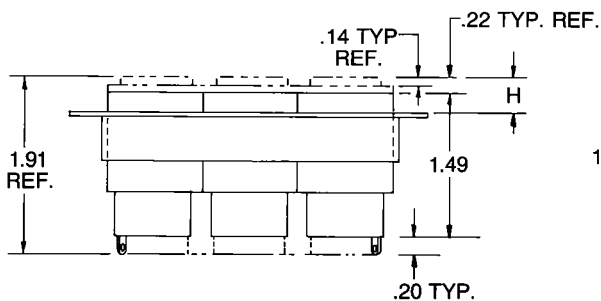

H=Flange Setback 0.28 min, 0.78 max

SERIES 5M MATRIX HOUSING TERMINATION RECEPTACLES

Termination receptacles, solder or PC, are normally furnished as part of the matrix housing. One receptacle is installed at rear of each matrix channel or station.

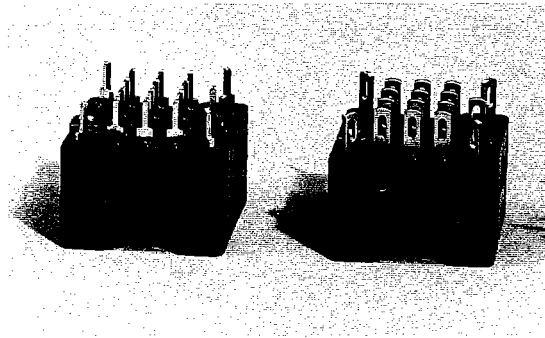

Style P
Printed Circuit Terminal

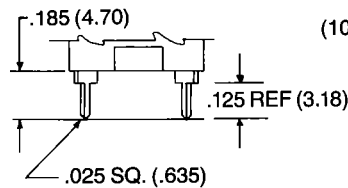

Style S
Solder Terminal

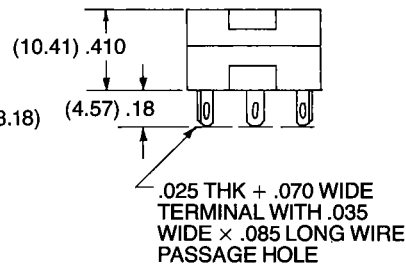

TERMINAL LAYOUT

Series 5M Matrix Receptacle

Receptacle used in all stations intended for any alternate, momentary, or indicator only module with common lamp ground.

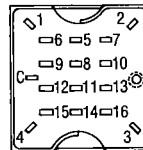

Mounting screw location for Switch/Indicator module.

Receptacle used in all stations intended for magnetically held modules with common lamp ground; or any alternate, momentary, or indicator only module with split lamp ground.

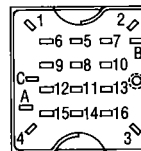

Series 505M Matrix Receptacle

Receptacles used in all stations regardless of type of switch or indicator module.

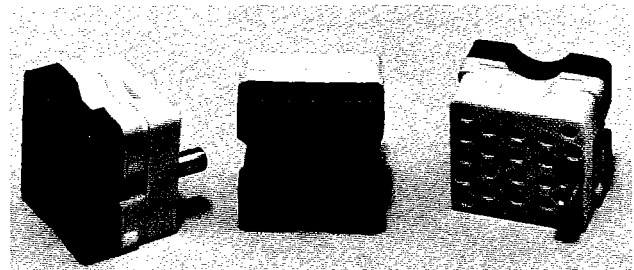
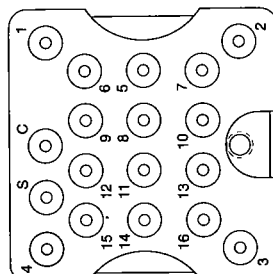

ORDERING INFORMATION

Series 505M Matrix Housing with Crimp Pin Termination Receptacles Series 5SM Matrix Housing, Indicator Only with Solder Terminals

TYPICAL PART NUMBER

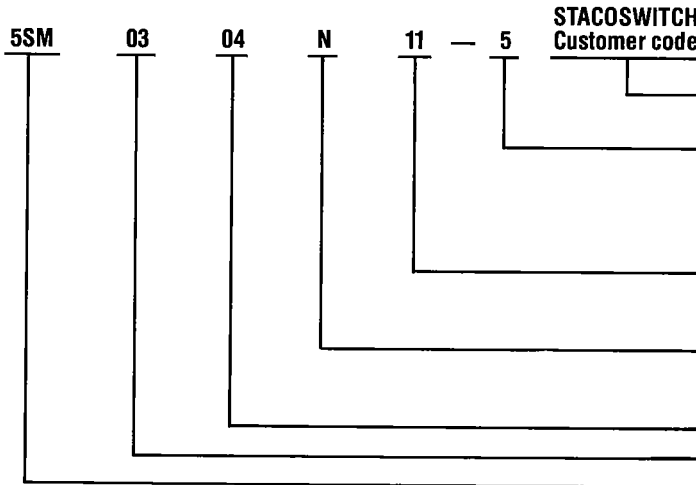

ASSEMBLY PART NUMBER CODE

Assigned by STACOSWITCH to define specific detail requirements of assemblies.

- 3 = Four flange configuration, rear mount
- 5 = Bezel, front mount, black anodize
- 7 = Bezel, front mount, clear anodize
- 9 = Bezel, front mount, RFI/EMI, irridite
- C = Bezel, front mount, colored finish

Flange set back in two-place decimal increments. (Dimension "H"; see page 7.) .110" fixed for front mount bezel. Use "11" as standard.

Shield options. N = Non-shielded, black anodize.
R = RFI/EMI shielded, irridite.

Number of vertical stations

Number of horizontal stations

Matrix Model: 505M, Crimp pin terminations

5SM, Indicator only, solder terminals/spade lugs

Series 5M Matrix Housing With PC Board or Solder Termination Receptacles

TYPICAL PART NUMBER

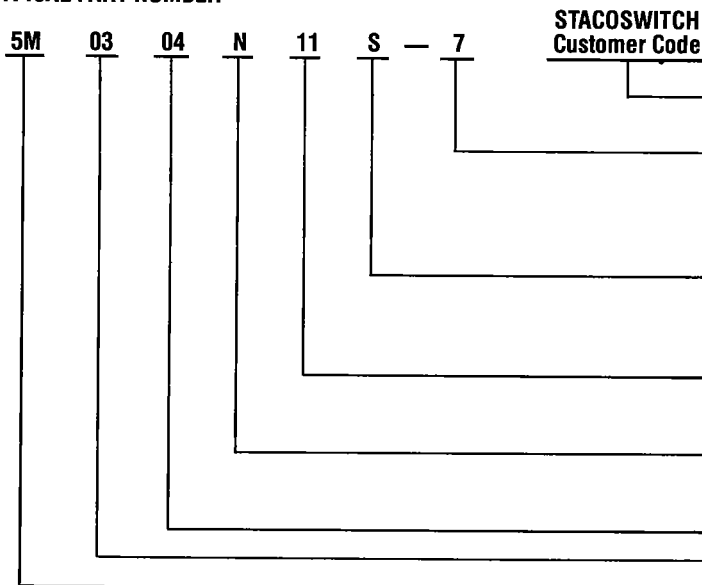

ASSEMBLY PART NUMBER CODE

Assigned by STACOSWITCH to define specific detail requirements of assemblies

- 3 = Four flange configuration, rear mount
- 5 = Bezel, front mount, black anodize
- 7 = Bezel, front mount, clear anodize
- 9 = Bezel, front mount, RFI/EMI, irridite
- C = Bezel, front mount, colored finish

Receptacle terminals:

- P = PC board type
- S = Solder lug type

Flange set back in two-place decimal increments. (Dimension "H"; see page 7.) .110" fixed for front mount bezel. Use "11" as standard.

Shield options. N = Non-shielded, black anodize.
R = RFI/EMI shielded, irridite.

Number of vertical stations

Number of horizontal stations

Matrix Model: 5M

Note: When specifying housing assemblies that will accommodate both common lamp grounds and/or split lamp grounds the intended location in matrix assembly must be designated.

ORDERING SYSTEMS

When ordering complete systems . . . matrix housing, switch/indicator modules, and pushbuttons . . . an Assembly Part Number can be assigned by the factory to cover the complete system. Each Channel or station within the matrix must be identified by a specific switch or indicator module and a Pushbutton Display Screen. Each station in the matrix is identified by a digit-dash-digit, called a Location Code.

The first digit in the Location Code identifies the horizontal row and the second digit identifies the vertical column. In the example 2-2 is the second row down and the second column to the right. Location 1-1 will always be top left as viewed by the OPERATOR. Pre-numbered worksheets are available from the factory on request.

TO SPECIFY A COMPLETE ASSEMBLED MATRIX SYSTEM FILL IN A CHART AS SHOWN BELOW:

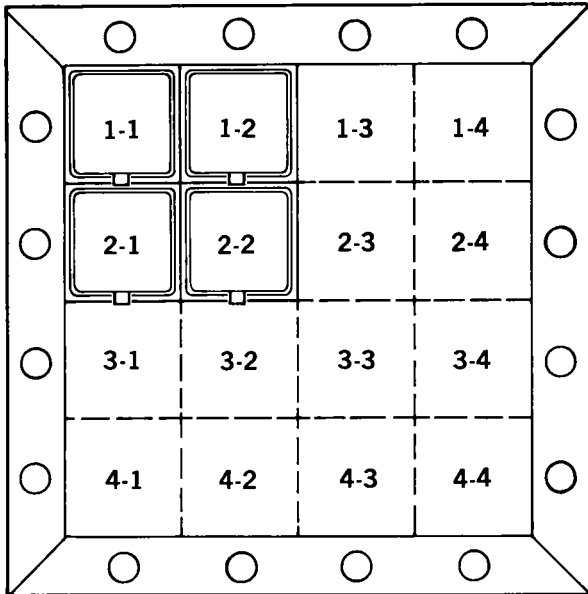

HOUSING ASSEMBLY P/N 5M/505M/5SMXXXXXX/XXX

LOCATION	SWITCH/INDICATOR MODULE PART NUMBER. See page 12, 13, or 14	PUSHBUTTON/DISPLAY SCREEN PART NUMBER. See page 18
1-1		
1-2		
1-3		
4-2	NOTE: Pre-numbered system worksheets available upon request.	
4-3		
4-4		

Termination Receptacles

Termination receptacles are normally supplied installed in the matrix housing. They may be ordered separately as replacements, however. Use appropriate part number code given below:

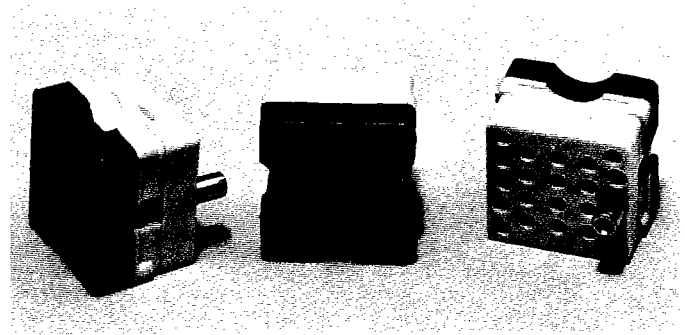
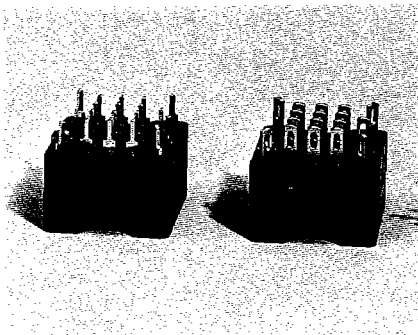

SERIES 5M MATRIX SYSTEM

Termination receptacle, Part Number 15066-XX mates with Series 5M Matrix Housing and Model 59 Individual Mount Switch/Indicator.

Basic Part Number	15066-	X	X
-1 = 4 PDT C.L.G.			
-2 = 2 PDT C.L.G.			
-3 = INDICATOR, S.L.G.			
-4 = 4 PDT, SOLENOID OR S.L.G.			
-5 = 2 PDT, SOLENOID OR S.L.G.			
-6 = INDICATOR STD. C.L.G.			
-7 = 4 PDT, SOLENOID, MATRIX MOUNTED			
-8 = 2 PDT, SOLENOID, MATRIX MOUNTED			
RECEPTACLE TERMINAL			
S = SOLDER			
P = PRINTED CIRCUIT			

SERIES 505M MATRIX SYSTEM

Crimp pin Termination Receptacle, Part Number 15073-X, mates with Series 505M Matrix Housing and Model 59C Individual Mount Switch/Indicator.

Basic Part Number	15073	X
01 = Indicator/CLG		
02 = 2PDT/CLG		
03 = 4PDT/CLG		
04 = Indicator/SLG		
05 = 2PDT/SLG		
06 = 4PDT/SLG		

CLG = Common Lamp Ground
SLG = Split Lamp Ground

MODEL 50M AND 50CM SWITCH/INDICATOR MODULES MODEL 50SM INDICATOR-ONLY MODULE

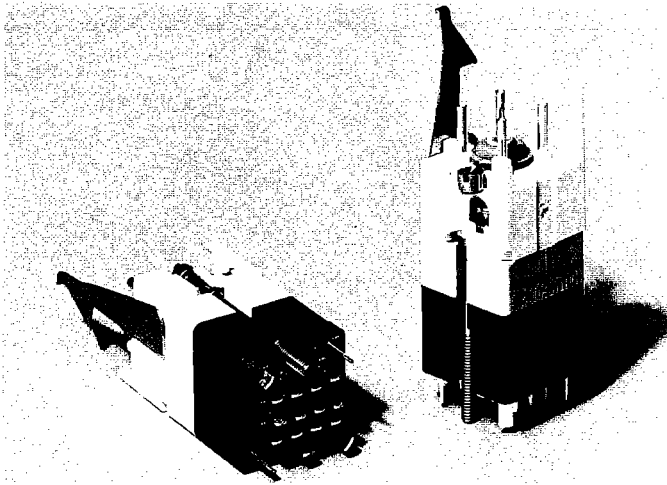

Model 50M Switch/Indicator Module

The Model 50M Switch/Indicator Module is used with the Series 5M Matrix Housing. The modules mate with solder or PC termination receptacles at the rear of each matrix station. Modules are available as 2PDT or 4PDT circuitry, common or split lamp ground, with momentary or alternate switch action, or as indicator only; or as 2PDT or 4PDT solenoid held switch with common lamp ground. Switches and indicators may be intermixed in the same matrix housing. Modules can be serviced from front of panel without having to touch behind-the-panel wiring. Pushbuttons can be from front of panel without special tools.

Model 50SM Indicator-Only Module

The Model 50SM Indicator-Only Modules is used with the Series 5SM Matrix Housing. Available with either common or split lamp ground the Model 50SM provides 4-lamp capability in a compact package. Solder terminals only. Allows relamping of pushbutton displays from front panel without special tools.

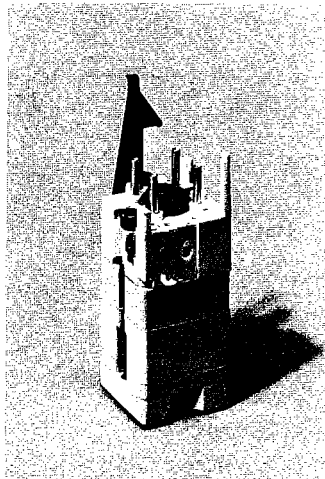
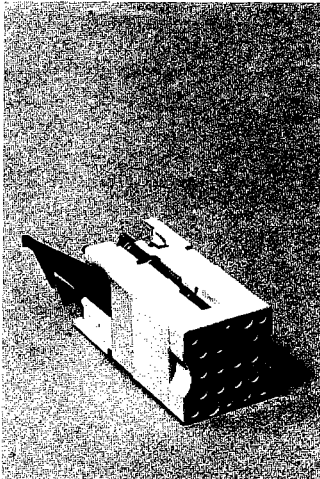
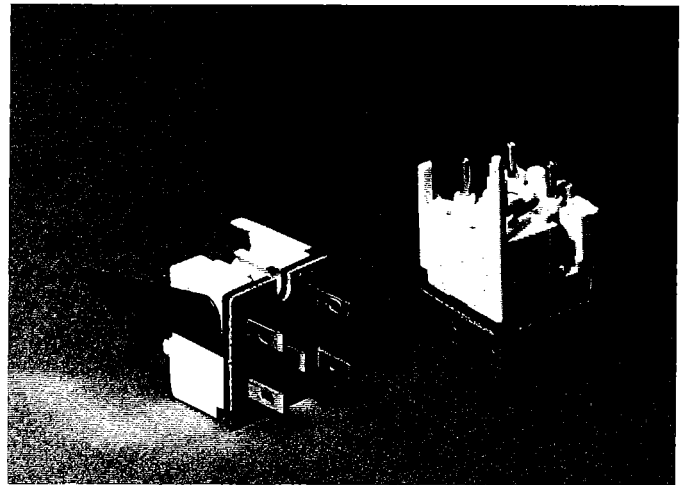

Model 50CM Switch/Indicator Modules

The Model 50CM Switch/Indicator Modules is used in the Series 505M Matrix Housing. Female connectors in the modules mate with retainer holes in the termination receptacle. Crimp pin connectors are securely held and maintain proper electrical contact, even under conditions of extreme shock and vibration. Modules are available as 2PDT or 4PDT circuitry, common or split lamp ground, with alternate or momentary switch action or as an indicator only. Switches and indicators may be intermixed in the same matrix housing. Both the modules and the display pushbuttons can be serviced from the front of the panel. Pushbuttons can be removed and relamped without use of special tools.

Schematic Diagrams

4PDT pushbutton switch schematic shown. For 2PDT omit terminals 8-13. For indicator only omit terminals 5-16. With momentary action switch terminals 6, 9, 12, and 15 are normally closed.

Series 50M and 50CM Models "A," "B" and "I"

Common
Lamp Ground

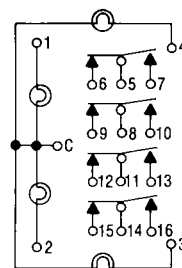

Split
Lamp Ground

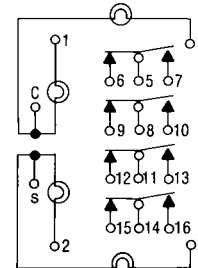

Series 50M Model "D"

Magnetically
Held Switch

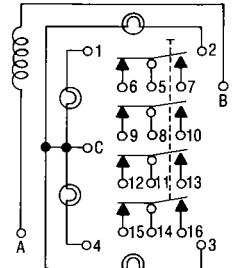

MODEL 50M SWITCH/INDICATOR MODULE

Dimensions, Part Number Codes, Specifications

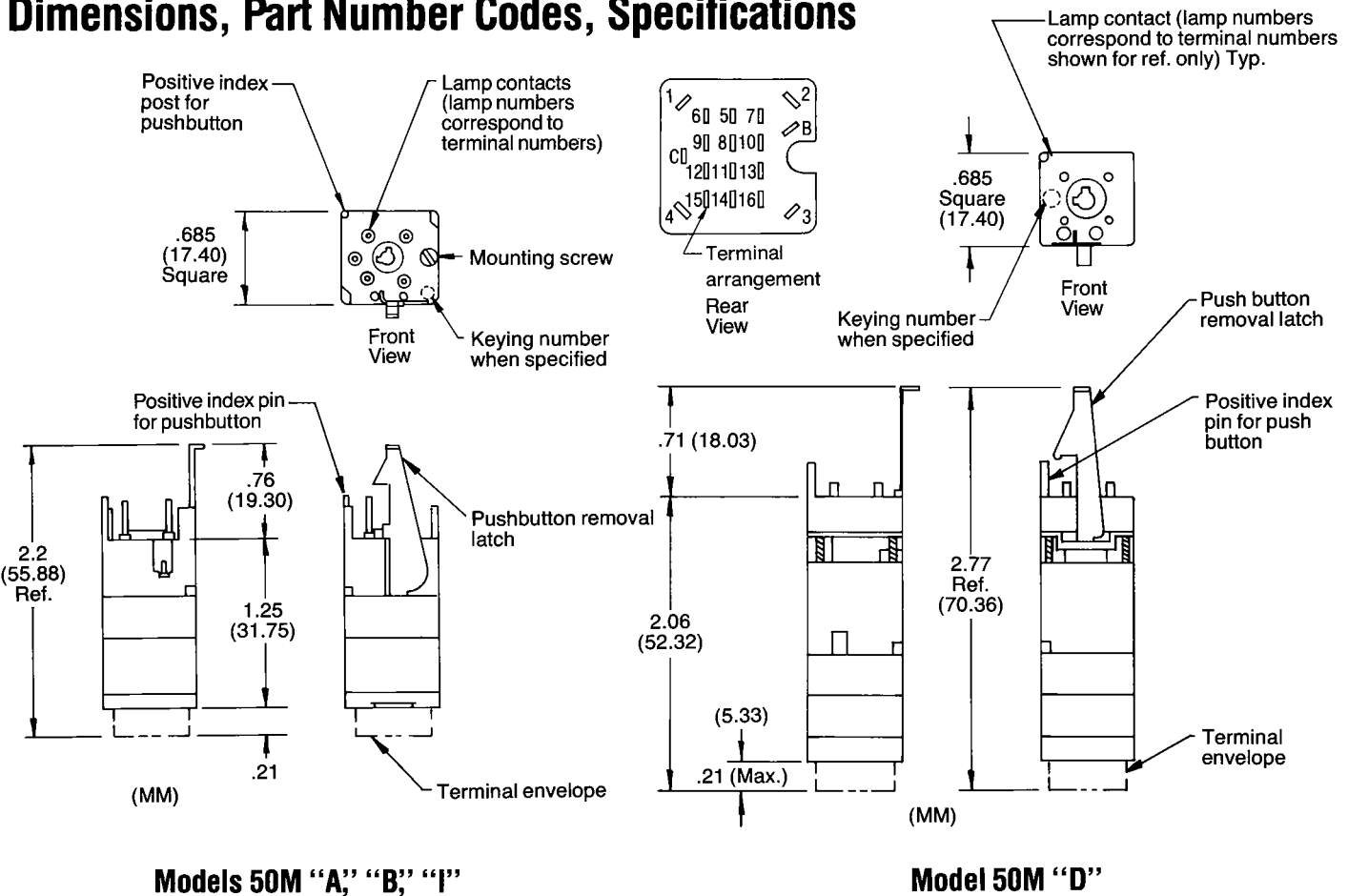

Specifications

ELECTRICAL

CONTACT RATINGS	28 VDC	115 VAC
Resistive	2.0 AMPS	2.0 AMPS
Inductive	1.0 AMP	1.0 AMP
Lamp	0.75 AMPS	0.75 AMPS
Dry Circuit	10 Microamp	

Contact Resistance025 ohms max.
 Dielectric 1000 VAC rms
 Insulation Resistance 1000 megohms min. @ 500 VDC

SOLENOID COIL—MODEL "D"

Coil Voltage, nominal 28 VDC
 Coil hold-in, minimum 20 VDC
 Coil resistance 420 ohms ± 10 % @ 25°C
 Duty cycle continuous

MECHANICAL

Operating Force C.L.G. 3.5 lbs. ± 1.0 lbs. (1.58 ± .45 KGM)
 S.L.G. 4.0 lbs. ± 1.0 lbs. (1.81 ± .45 KGM)

Travel
 Models "A," "B" and "D" 200" max. (5.08)
 Life 50,000 cycles

ENVIRONMENTAL: Meets or exceeds applicable Military Specification MIL-S-22885 for salt spray, moisture resistance, dripproof, thermal shock, vibration, and sand, dust, and fungus resistance.

Ordering Information

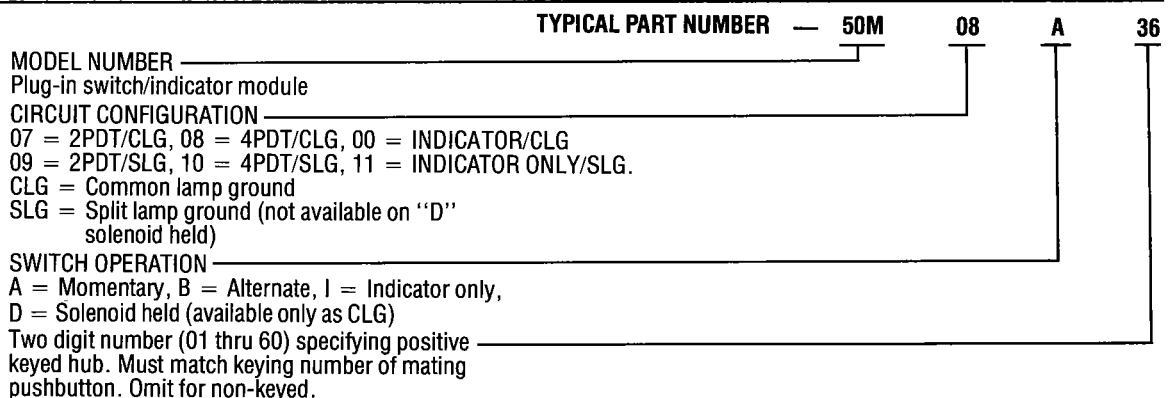

MODEL 50CM SWITCH/INDICATOR MODULE

Dimensions, Part Number Codes, Specifications

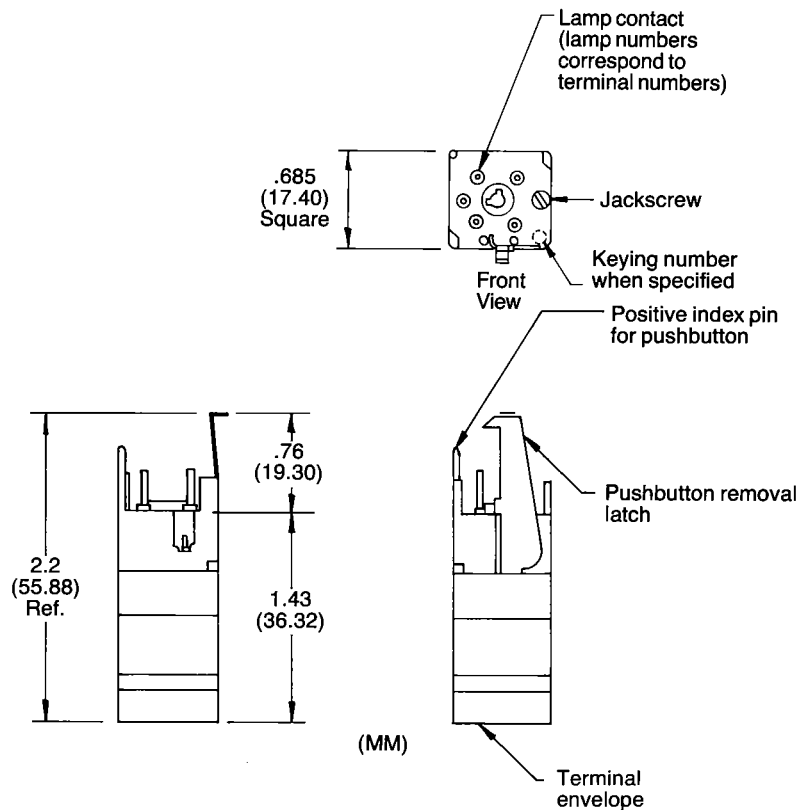

Specifications

MECHANICAL: A. Actuation Force, C.L.G. 3.5 lbs. \pm 1.0 lbs. (1.58 \pm .45 KGM)
 S.L.G. 4.0 lbs. \pm 1.0 lbs. (1.81 \pm .45 KGM)
 B. Actuation Travel, .200 (5.08) Maximum
 C. Weight, .032 Pound (14.53) \pm 10%
 D. Life, 50,000 Mechanical Cycles
 E. Wire Termination, Insertion and Removal Force as defined in MS3197.

ELECTRICAL: A. Life at rated load, 25,000 Cycles, minimum
 B. Contact Load Rating, 28 VDC 115 VAC
 Resistive 2 AMPS 2 AMPS
 Inductive 1 AMP 1 AMP
 Lamp .75 AMP .75 AMP
 Dry Circuit, 10 Microamps
 (10 Millivolts to 28 VDC)

C. Contact Resistance Switch Lamp
 Initial .025 Ohm, Max. 1.0 Ohm, Max.
 D. Dielectric Strength
 Sea Level, 1,056 VRMS
 70,000 Feet, 450 VRMS
 E. Insulation Resistance, 1,000 Megohms @ 500 VDC

ENVIRONMENTAL: Meets or exceeds applicable Military Specification MIL-S-22885 for salt spray, moisture resistance, dripproof, thermal shock, vibration, and sand, dust, and fungus resistance.

Ordering Information

Model Number—Matrix Crimp Pin Switch/Indicator Module

	50CM	XX	X	XX
Circuit Configuration	07=2PDT/CLG, 08=4PDT/CLG, 00=Indicator/CLG			
	09=2PDT/SLG, 10=4PDT/SLG, 11=Indicator/SLG			
Switch Operation	A=Momentary, B=Alternate, I=Indicator Only			
Two Digit Number (01 thru 60) specifying positive keyed hub. Must match keying number mating pushbutton. Omit for non-keyed				
SLG=Split Lamp Ground				
CLG=Common Lamp Ground				

MODEL 50SM INDICATOR MODULE

Dimensions, Part Number Codes, Specifications

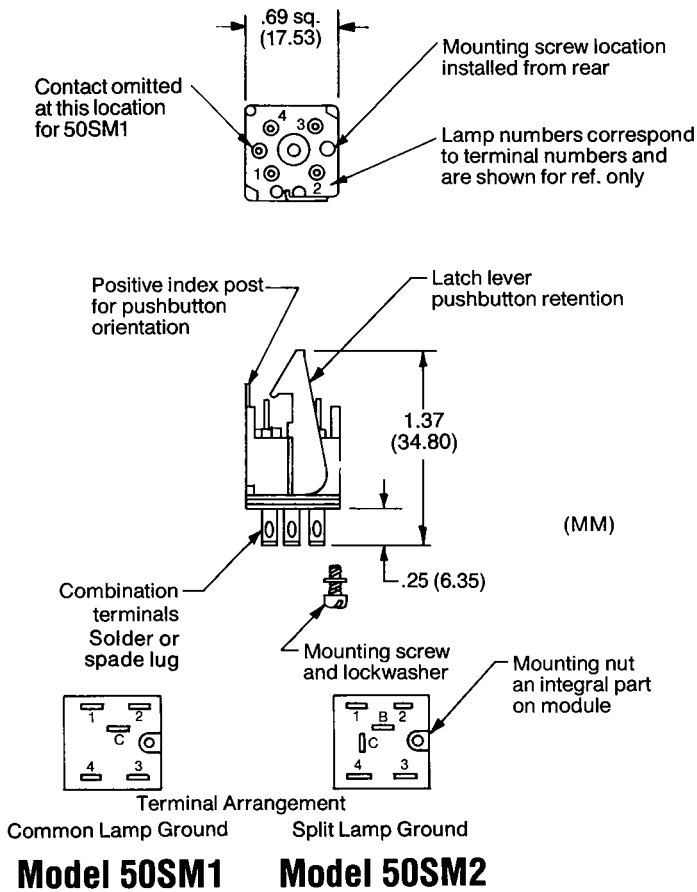

Specifications

1. **MECHANICAL:** A. Weight, 8 gms
B. Life, 1000 hrs. (minimum)

2. **ELECTRICAL:** A. Lamp Circuit Resistance, 0.5 ohm max.
B. Dielectric, 1056 vrms
C. Insulation Resistance, 500 megohm

ENVIRONMENTAL: Meets or exceeds applicable Military Specification MIL-S-22885 for salt spray, moisture resistance, drip-proof, thermal shock, vibration, and sand, dust, and fungus resistance.

Schematic Diagrams

Common Lamp Ground

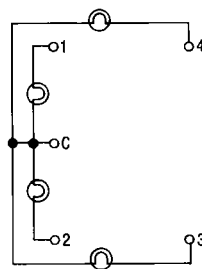

Split Lamp Ground

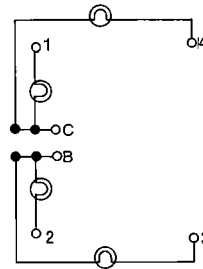

Ordering Information

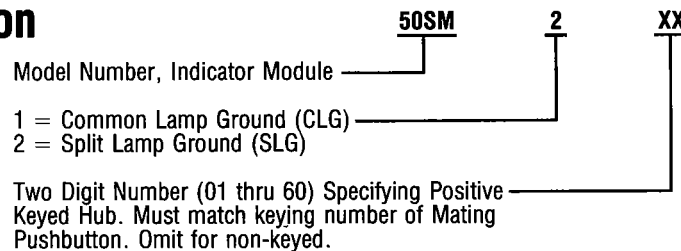

SERIES 50 LIGHTED DISPLAY PUSHBUTTON, DRIPPROOF

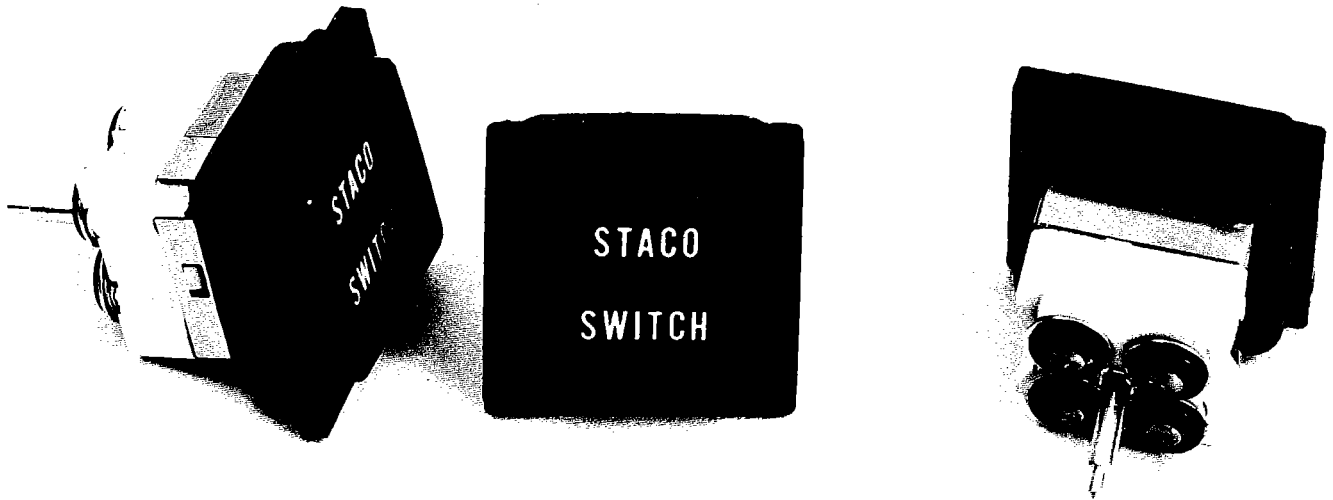

Series 50 Lighted Display Pushbuttons are manufactured to meet the dripproof requirements of MIL-STD-108, along with all the other environmental requirements of MIL-S-22885. Designed to operate with four T-1-3/4 midget flange base incandescent lamps, the pushbuttons are used with Series 5M, 5SM, and 505M Matrix Systems and Models 59 and 59C Individual Mount Switch/indicators.

DRIPPROOF SEAL—The pushbutton's captive rubber seal snugly mates with the matrix housing or switch/indicator body, effectively closing off all possible paths for the passage of water into the switch. A rubber gasket seals the face plate to the pushbutton body eliminating any possible openings. The design of the pushbutton captive rubber seal allows unrestricted movement of the pushbutton for ease of switch actuation. There is no increase in operating force because of the rubber seal.

STANDARD DISPLAY OPTIONS—Choice of eight legend illumination types, eight display screen styles, and six colors for the legend or the display background. One to four levels of information can be displayed individually or in combination with legend copy, set to your specifications, limited only by space available on the display panel.

Stacoswitch's long proven, QPL, Legend Display Types Nos. 1 through 6 & 8 offer design engineers a wide range of configurations and color combinations for distinctive message displays. Designer matched colors

enhance display appearance and contribute to increased operator efficiency.

SUNLIGHT READABLE LIGHTED DISPLAYS—For critical lighting areas where high ambient light creates severe glare, Sunlight Readable Legends are clearly legible...even when viewed in a 10,000 footcandle light. Legend Display Type No. 9 eliminates loss of legend readability due to reflection or glare. Display illumination is uniform across full panel area with no hot spots, even when dimmed for night viewing. Unlighted display has a black, dead front panel. Hidden message does not appear energized in 10,000 footcandle ambient light.

For maximum sunlight readability a legend height of .125" is recommended as this provides optimum degree of contrast between the lighted legend and the unlighted black background. Lamps of .15 MSCP (Mean Spherical Candle Power) must be used if correct degree of sunlight readability is to be achieved. See page 23 for lamp ordering information.

LAMP CIRCUITRY—Pushbuttons are available with either common lamp ground (CLG) for all four lamps, or with a split lamp ground (SLG) where lamps 1 and 4 are common and lamps 2 and 3 are common. For a vertical SLG 2-way split display mount switch/indicator with the latch lever at bottom of the pushbutton, as shown below. For a horizontal SLG 2-way split display rotate switch/indicator 90° and mount with the latch lever to the left side of the pushbutton, unless otherwise specified. CLG switch/indicators are always mounted with the latch lever at bottom of the pushbutton, regardless of style of display.

Specifications

MECHANICAL: A. Weight, including lamps: .028 lbs.
B. Faceplate will withstand 40 pound distributed load.
C. Relamping accomplished without use of tools

ELECTRICAL: A. Dielectric Strength
Sea Level 1,056 VRMS
70,000 feet 450 VRMS
B. Insulation Resistance 1,000 MEGOHMS @ 500VDC

ENVIRONMENTAL: Meets or exceeds applicable Military Specification MIL-S-22885 for salt spray, moisture resistance, dripproof, thermal shock, vibration, and sand, dust, and fungus resistance.

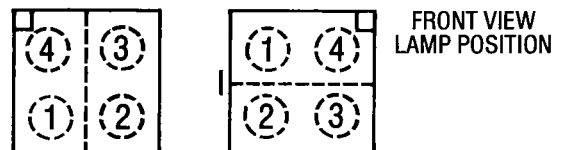

Ref. Latch lever position when switch/indicator module installed.

SERIES 50 LIGHTED DISPLAY PUSHBUTTON, DRIPPROOF

Circuit Diagrams

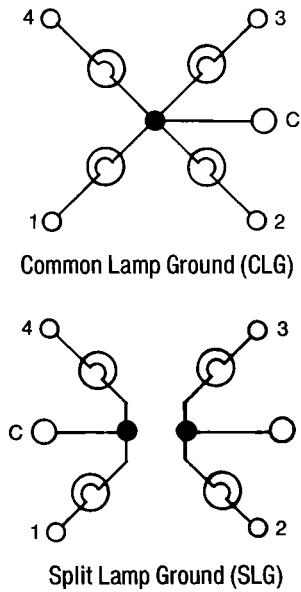

Pushbutton

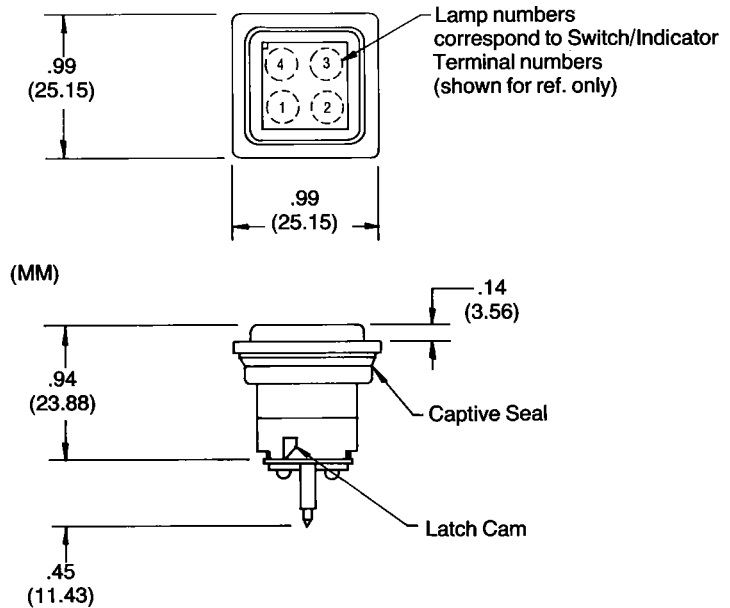

Chart No. 1 Pushbutton Type

Refer to ordering information

MODEL	DESCRIPTION	HIGH SHOCK	MODEL	DESCRIPTION	HIGH SHOCK
T	Basic Pushbutton, Common Lamp Ground	E	J	Basic Pushbutton, Split Lamp Ground	G
U	RFI Shielded, Common Lamp Ground	F	L	RFI Shielded, Split Lamp Ground	H

Chart No. 2 Display Type

Refer to ordering information

TYPE	NON-ILLUMINATED		ILLUMINATED	
	LEGEND	BACKGROUND	LEGEND	BACKGROUND
01	Black	Translucent Color	Black	Color
02	Not Easily Discernible	Translucent White	Black	Color
03	Translucent Color	Black	Visible in Color	Black
04	Not Easily Discernible	Appears Translucent White	Visible in Color	Opaque
05	Black Filled Engraving on External Surface	Translucent White Face Plate	Black	Color
06	Translucent White	Black	Visible in Color	Black
08	Black	Translucent White	Black	Color
09	Not Easily Discernible	Black	Visible in Color	Black
10	Always Visible White (AVW)	Black	Visible in Color	Black

Types 1 thru 6 and 8

Nominal luminance values for standard color filters shown in Chart No. 4, when illuminated by MS25237-327 lamps of $0.34 \pm .02$ mean spherical candlepower at 28 VDC. This table for reference only.

Type 9

Sunlight readable display, ie—when energized, display shall be readily discernible under 10,000 F.C. and when not energized, display shall not be discernible. Legend height of .125 is recommended.

SERIES 50 LIGHTED DISPLAY PUSHBUTTON, DRIPPROOF

Chart No. 3—Display Styles and Legend Areas

Refer to ordering information

DISPLAY STYLE CODE	LEGEND AREA	CHARACTERS PER COLUMN OR LINE MAX. NO.				COLUMNS OR LINES PER AREA MAX. NO.					
		CHAR. HGT.	LEGEND AREA				CHAR. HGT.	LEGEND AREA			
			1	2	3	4		1	2	3	4
A	1	.100	8				.100	5			
		.125	6				.125	3			
		.187	3				.187	2			
B	1	.100	8	8			.100	2	2		
	2	.125	6	6			.125	1	1		
		.187	3	3			.187	1	1		
C	1 2	.100	3	3	8		.100	2	2	2	
	3	.125	3	3	6		.125	1	1	1	
		.187	2	2	3		.187	1	1	1	
D	1	.100	8	3	3		.100	2	2	2	
	2 3	.125	6	3	3		.125	1	1	1	
		.187	3	2	2		.187	1	1	1	
E	1 2	.100	3	3	3	3	.100	2	2	2	2
	3 4	.125	3	3	3	3	.125	1	1	1	1
		.187	2	2	2	2	.187	1	1	1	1
F	1 2	.100	5	5			.100	2	2		
	2	.125	3	3			.125	1	1		
		.187	2	2			.187	1	1		
G	1 2	.100	5	2	2		.100	2	2	2	
	3	.125	3	1	1		.125	1	1	1	
		.187	2	1	1		.187	1	1	1	
H	1 3	.100	2	2	*5		.100	2	2	2	
	2	.125	1	1	*3		.125	1	1	1	
		.187	1	1	*2		.187	1	1	1	

EXAMPLES
TYPICAL LEGEND
ARRANGEMENTS

BYPASS
PUMP
CHECK

AUTO
MANUAL

A B
MOTOR

POWER
ON OFF

A-1 B-1
B-2 A-2

M O V E
S T O P

P A R T
GO
NO GO

AC
DC
E L E C

Chart No. 4—Legend Area Colors

Refer to ordering information

Color	Code	Nominal Brightness in Foot Lamberts for Legend Display Types				Sunlight Readable Color Readability (Relative Values)
		1 and 3	2 and 4	5	6 and 8	9
Blue	B	25	35	20	35	Good
Green	G	160	190	90	190	Very Good
Red	R	160	190	90	190	Very Good
White	W	300	400	150	250	Excellent
Amber	A	190	220	90	220	Excellent
Yellow	Y	300	375	150	375	Excellent

1. With RFI screen. Display brightness diminished approx. 60% of the above.
2. Colors are in accordance with MIL-S-22885/56; red and yellow are also in accordance with MIL-C-25050.

SERIES 50 LIGHTED DISPLAY PUSHBUTTON, DRIPPROOF

Legends

Standard legend heights are .100", .125", or .187". The character format for photographic alpha-numeric legends is Alternate Gothic No. 2. Character format for engraved alpha-numeric legends is Groton Condensed. Display Types 1, 2, 3, 4, 6, and 8 (see Chart No. 2) employ photographic film legends installed behind the pushbutton face plate.

Display Type 5 is an engraved legend with a contrasting color fill. Display Type 9 is a Sunlight Readable Legend for optimum readability even when viewed in a 10,000 footcandle ambient light. In the unlighted condition Display Type 9 legend is "hidden" behind a black dead front panel.

Keyed Pushbuttons

Pushbuttons can be supplied with a keying feature that allows only identically keyed switch or indicator and pushbutton to mate. This feature guards against the possibility of the pushbutton being inserted in the wrong switch or indicator position. Up to 60 non-interchangeable keyed configurations are available.

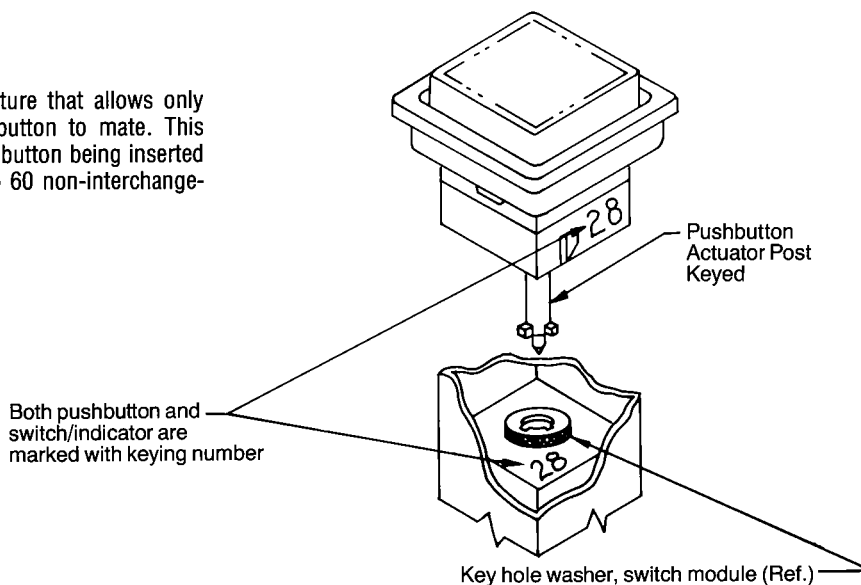

Ordering Information

TYPICAL PART NUMBER	50	T	00	02	B	2	R	G	X	X	(Auto)	(Manual)	(X)	(X)
Series 50 Sealed Pushbutton and Display Screen	_____	_____	_____	_____	_____	_____	_____	_____	_____	_____	_____	_____	_____	_____
Pushbutton Model (T, U, J, L) Chart No. 1	_____	_____	_____	_____	_____	_____	_____	_____	_____	_____	_____	_____	_____	_____
Pushbutton Keying (01 thru 60 when specified) (00 when not req'd.)	_____	_____	_____	_____	_____	_____	_____	_____	_____	_____	_____	_____	_____	_____
Display Type (01-10) Chart No. 2	_____	_____	_____	_____	_____	_____	_____	_____	_____	_____	_____	_____	_____	_____
Display Style (A thru E) Chart No. 3	_____	_____	_____	_____	_____	_____	_____	_____	_____	_____	_____	_____	_____	_____
Legend Height, 1 = .100, 2 = .125, 3 = .187	_____	_____	_____	_____	_____	_____	_____	_____	_____	_____	_____	_____	_____	_____
Area 1 Color Code	_____	_____	_____	_____	_____	_____	_____	_____	_____	_____	_____	_____	_____	_____
Area 2 Color Code	_____	_____	_____	_____	_____	_____	_____	_____	_____	_____	_____	_____	_____	_____
Area 3 Color Code	_____	_____	_____	_____	_____	_____	_____	_____	_____	_____	_____	_____	_____	_____
Area 4 Color Code	_____	_____	_____	_____	_____	_____	_____	_____	_____	_____	_____	_____	_____	_____
Area 1 Legend	_____	_____	_____	_____	_____	_____	_____	_____	_____	_____	_____	_____	_____	_____
Area 2 Legend	_____	_____	_____	_____	_____	_____	_____	_____	_____	_____	_____	_____	_____	_____
Area 3 Legend	_____	_____	_____	_____	_____	_____	_____	_____	_____	_____	_____	_____	_____	_____
Area 4 Legend	_____	_____	_____	_____	_____	_____	_____	_____	_____	_____	_____	_____	_____	_____

Note: Enclose legend for each area in parenthesis. Use an X for legend areas not used. Separate lines in each area by a semi-colon.

Example: (AUTO; POWER) (MANUAL; POWER) (X) (X)

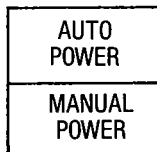

SERIES 50 SWITCH/INDICATORS

PROVEN DEPENDABILITY—Series 50 Dripproof Individually Mounted Switches and Indicators use Stacoswitch's long proven, ruggedly dependable components. The same switching assembly used in Stacoswitch's QPL Series 40 Switches are used in the Series 50 Switches. These switch modules have long history of successful service in military, critical industrial, and medical equipment applications. This same dependability is available in the Series 50 Switch/Indicators. Contact materials are high conductivity precious metal alloy, gold plated for optimum contact reliability.

EASY INSTALLATION AND MAINTENANCE—Series 50 Switch/Indicators mount in a 1.00" square panel opening. The switch/indicator housing is simply inserted into the mounting hole from the front of the panel and the mounting sleeve is then slid onto the housing from the rear of the panel. Tightening the retainer screw securely clamps the assembly to the panel. All lamp and switch terminations are on the same plane for ease of wiring. Switch/Indicator modules can be replaced from the front of the panel without touching behind the panel wiring. Pushbuttons can also be easily relamped from the front of the panel without special tools.

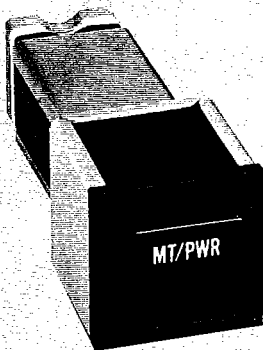
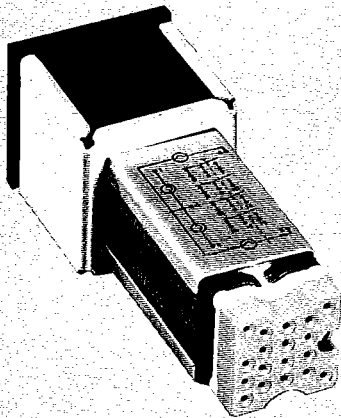
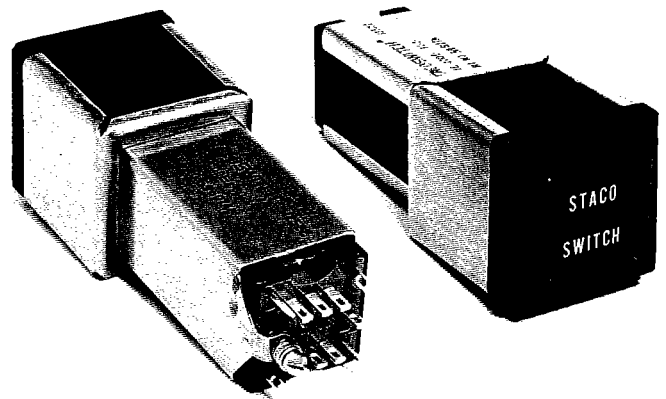

MODEL 59 SWITCH/INDICATOR—Individually mounted unit offering the same design features and advantages as the Series 5M Matrix Mounted System. Choice of solder or printed circuit terminations. Single plane wiring, with all lamp and switch terminals on the same level simplifies installation with savings in time and labor. Choice of momentary or alternate switch action with 2PDT or 4PDT circuitry, and common or split lamp ground. Solenoid held switch available with either 2PDT or 4PDT circuitry and common lamp ground. Indicator only unit, with common or split lamp ground, has no switch action and is intended to serve as a warning light.

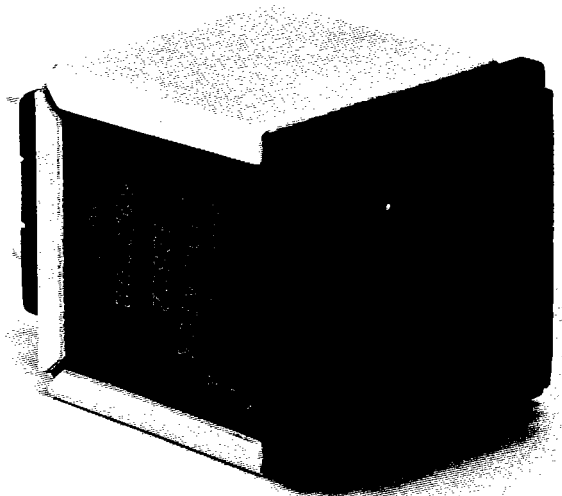

MODEL 59C SWITCH/INDICATOR—Individually mounted unit offering the same design features and advantages as the Series 505M Matrix Mounted System. The termination receptacle accepts male crimp pin connectors on #20, #22, or #24 wire. Mating retainer holes in termination receptacle and female connectors in the switch/indicator module securely hold crimp pin connectors and maintain proper electrical contact. Choice of momentary or alternate switch action with 2PDT or 4PDT circuitry, indicator only, and common or split lamp ground. Indicator only unit has no switch action and is intended to serve as a warning light.

MODEL 52 INDICATOR—Individually mounted counterpart to the Series 5SM Matrix Mounted System. Using the same Series 50 Pushbuttons as the switches, the Model 52 Indicator provides look-alike appearance when grouped with the Model 59 or 59C Switches. Compact design requires only 1.53" depth behind the panel face. Terminations are combination solder and spade lug, and are available either as common or split lamp ground.

MODEL 59 SWITCH/INDICATORS WITH SOLDER OR PC TERMINATION RECEPTACLES

Schematic Diagrams

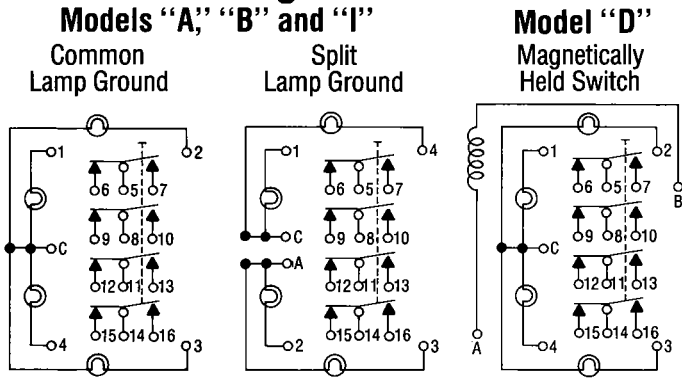

Pushbutton switch schematic 4PDT Shown.
For 2PDT, Omit terminals 8-13. For Indicator, Omit terminals 5-16.

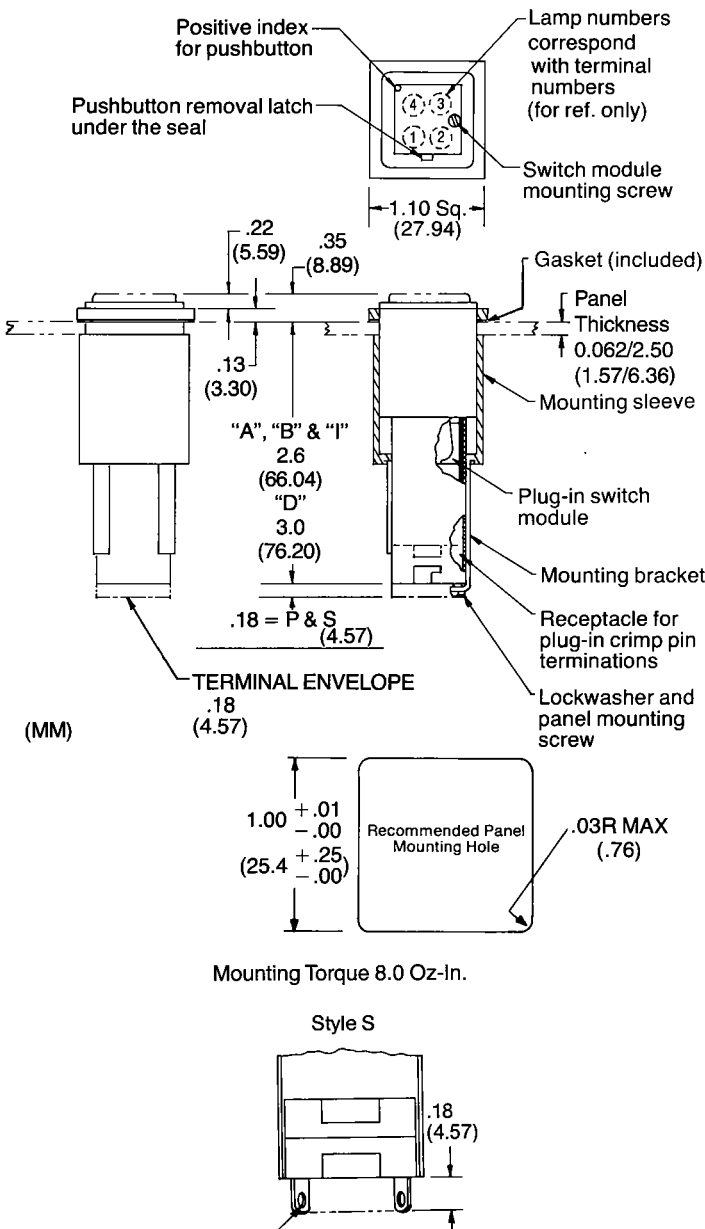

Mounting Torque 8.0 Oz-In.

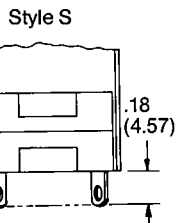

.025 thk. X .070 wide terminal with (.635 X 1.78)
.035 wide X .085 long wire passage hole (.89 X 2.16)

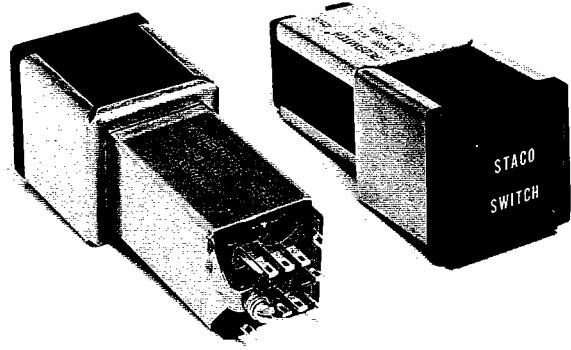

ELECTRICAL

CONTACT RATINGS	28 VDC	115 VAC
Resistive	2.0 AMPS	2.0 AMPS
Inductive	1.0 AMP	1.0 AMP
Lamp	0.75 AMPS	0.75 AMPS
Dry Circuit	10 Microamp	

Contact Resistance0.25 ohms max.
Dielectric1000 VAC rms
Insulation Resistance1000 megohms min. @ 500 VDC
Life25,000 cycles

SOLENOID COIL—MODEL "D"

Coil Voltage, nominal28 VDC
Coil hold-in, minimum20 VDC
Coil resistance420 ohms ±10% @ 25°C
Duty cyclecontinuous

MECHANICAL

Operating Force3.5 lbs. ±1.0 lb.
Travel
Models "A", "B" and "D" ...200" max.

Life50,000 cycles

ENVIRONMENTAL: Meets or exceeds applicable Military Specification MIL-S-22885 for salt spray, moisture resistance, drip-proof, thermal shock, vibration, and sand, dust, and fungus resistance.

Ordering Information

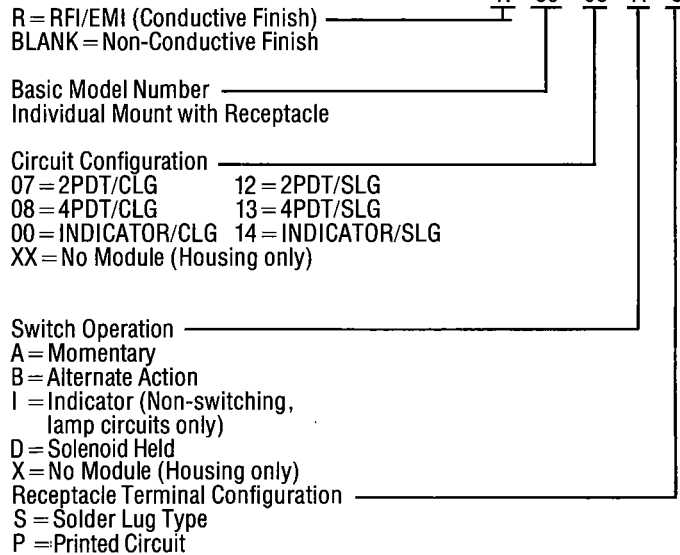

CLG = Common Lamp Ground
SLG = Split Lamp Ground

MODEL 59C SWITCH/INDICATORS WITH CRIMP PIN TERMINATION RECEPTACLES

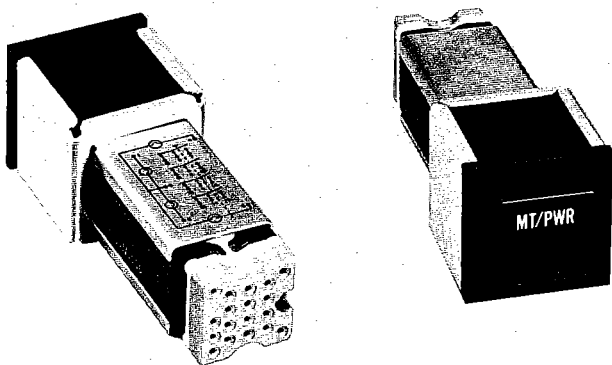

Schematic Diagrams

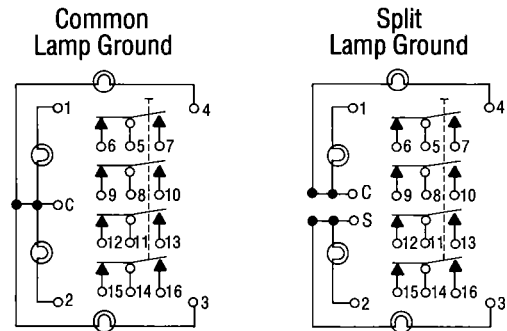

4PDT pushbutton switch schematic shown. For 2PDT omit terminals 8-13. For indicator only omit terminals 5-16. With momentary action switch terminals 6, 9, 12, and 15 are normally closed.

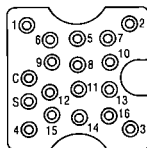
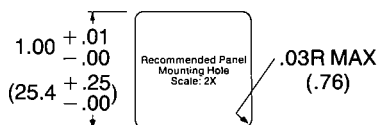
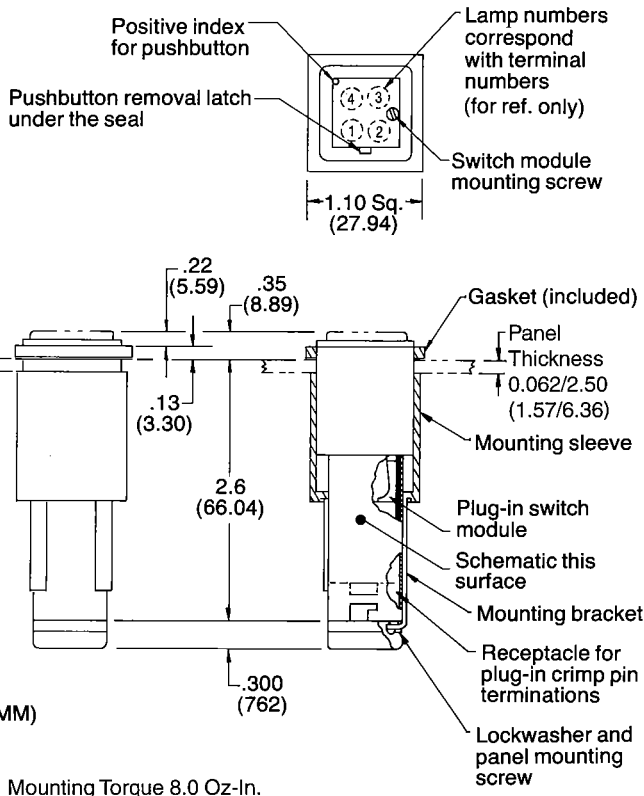

ELECTRICAL

CONTACT RATINGS	28 VDC	115 VAC
Resistive	2 AMPS	2 AMPS
Inductive	1 AMP	1 AMP
Lamp	.75 AMPS	.75 AMPS
Dry Circuit	10 Microamps	

Life at rated load 25,000 cycles min.
 Contact resistance, initial Switch—.025 ohms max.
 lamps—1.0 ohms max.
 Dielectric Strength Sea level—1,056 vrms
 Insulation resistance 1,000 megohms @ 500 vdc

MECHANICAL

Actuation force 3.5 ± 1.0 pounds
 Actuation travel200 inch max.
 Life 50,000 mechanical cycles

ENVIRONMENTAL: Meets or exceeds applicable Military Specification MIL-S-22885 for salt spray, moisture resistance, drip-proof, thermal shock, vibration, and sand, dust, and fungus resistance.

Ordering Information

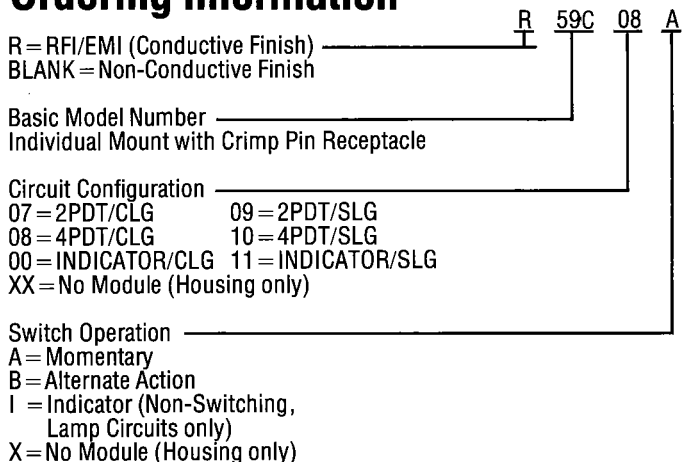

CLG = Common Lamp Ground
 SLG = Split Lamp Ground

MODEL 52 INDICATOR

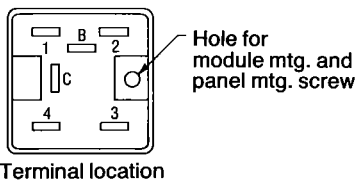
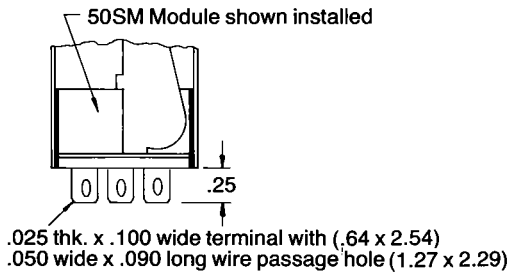
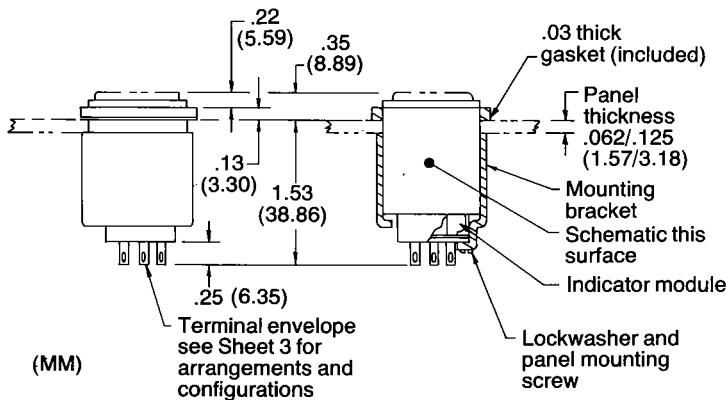
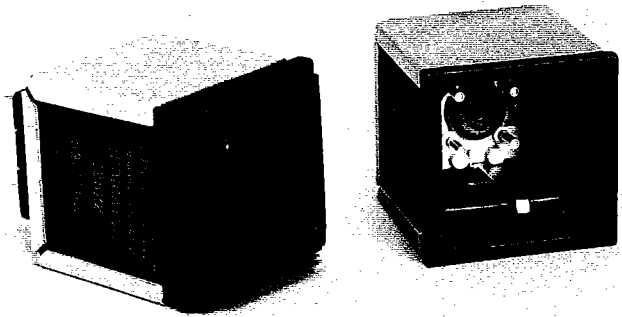
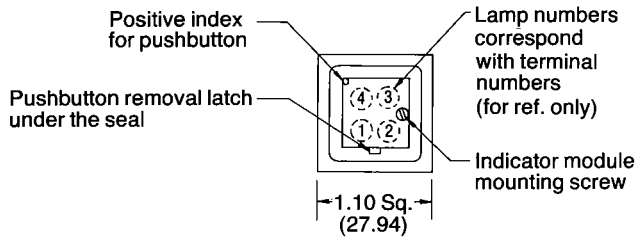

Mounting Torque 8.0 Oz-In.

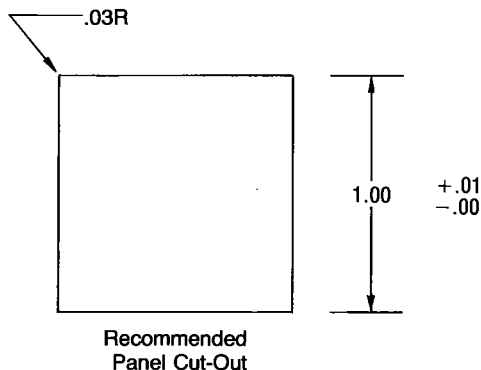

Schematic Diagrams

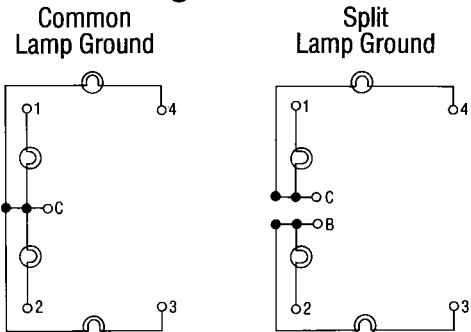

Specifications

- MECHANICAL:** A. Weight, 20 gms (Incl. Pushbutton/Display)
 B. Life, 1000 hrs. (minimum)
- ELECTRICAL:** A. Lamp Circuit Resistance, 0.5 ohm max.
 B. Dielectric, 1056 VRMS
 C. Insulation Resistance, 500 megohm
- ENVIRONMENTAL:** Meets or exceeds applicable Military Specification MIL-S-22885 for salt spray, moisture resistance, drip-proof, thermal shock, vibration, and sand, dust, and fungus resistance.

Ordering Information

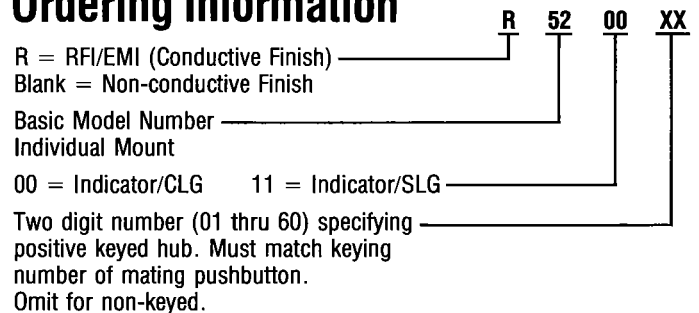

Note: Due to the number of variable features offered, the Pushbutton/Display Screen must be ordered separately. Refer to Series 50 Specification Control Drawing for ordering information.

CLG = Common Lamp Ground
 SLG = Split Lamp Ground

CONTROLLERS

Dimmer

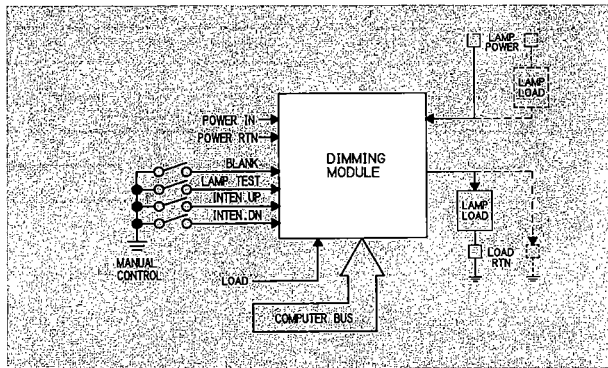

Interface Controller

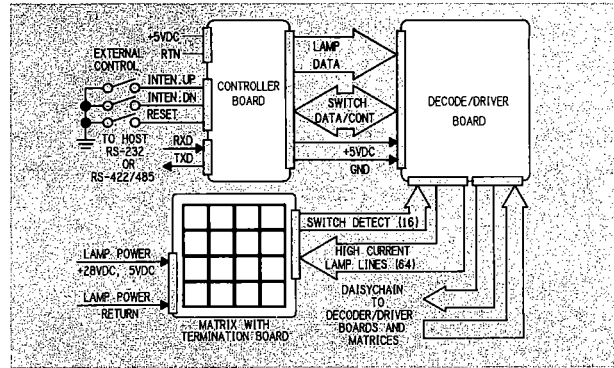

FOR DIMMING OF BOTH LED AND INCANDESCENT DEVICES

FOR MULTIPLEXING AND CONTROL OF LIGHTING AND SWITCH FUNCTIONS

- LED and Incandescent Dimming
- 16 Levels of Brightness Control
- Full Brightness
- Full Blank Lamp Test
- Remote UP/DOWN Input
- 4 Bit Digital Input
- Sourcing or Sinking
- Full Mil Spec Construction
- Specify Part Number DDM111
- Catalog Number GC - 6/9

- Control of Up to 256 Outputs (Lamps)
- Control of Up to 64 Inputs (Switches)
- Receipt and Execution of Host Commands
- Power Up Diagnostics
- LED or Incandescent Lamp ON/OFF Control
- 32 Levels of Brightness Control
- Mil Spec or Industrial Versions
- RS232, RS422 or RS485 Compatible
- Specify Part Number IFC211
- Catalog Number GC - 6/9

STACO SWITCH

A Components Corporation of America Company

1139 Baker Street • Costa Mesa, CA 92626-4191
 Telephone: 714.549.3041 • Fax: 714.549.0930
 e-mail: sales@stacoswitch.com
 http://www.stacoswitch.com