

# Lighted Pushbutton Switches

Series 80 Sunlight Readable



A Components Corporation of America Company

Sunlight Readable  
Lighted Pushbutton  
Display Switches  
And Indicators

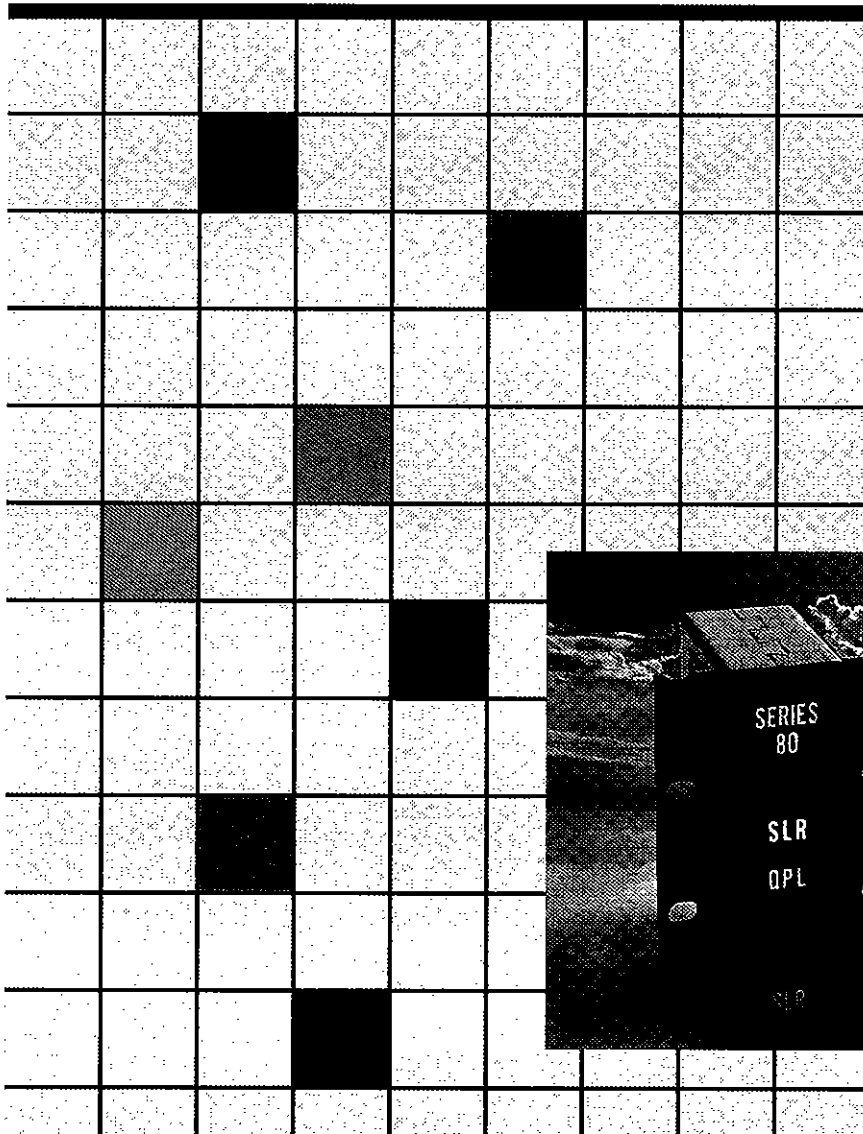

# SERIES 80 SUNLIGHT READABILITY

## Sunlight Readable

Illuminated legend is clearly legible in 10,000 foot candle ambient light. This is equivalent to direct sunlight at 70,000 ft. Completely eliminated is the problem of loss of legend readability due to reflection of bright ambient on the display panel.



## Dead Front Panel

When not lighted the legend does not appear energized and is not discernible when viewed in the same 10,000 foot candle ambient light. Positive identification of display information or absence of information is assured.



## Sunlight Readable Colors



Only Stacoswitch's Series 80 offers six design proven Sunlight Readable colors. Amber, yellow, white, red, green and blue...each readily readable in 10,000 foot candles ambient light and each in accordance with MIL-S-22885 and MIL-C-25050. Stacoswitch's lighted display knowhow that made us a leader in illuminated switch technology has also made us a leader in Sunlight Readability technology.

## No Legend Washout

Until Stacoswitch's Series 80, reflected glare or direct sunlight on control panel surfaces in aircraft crew stations, or any area exposed to bright ambient light, was a major problem faced by avionic designers and human factor engineers. With today's high performance aircraft and its advanced electronics, fast and positive identification of displayed information is a major importance. Stacoswitch's Series 80 Sunlight Readable Display Switch/Indicators have completely eliminated the problem of loss of legend readability due to reflection of bright ambient light.

## Sunlight Readability Explained

Until recently the major efforts of illuminated switch designers to improve readability of lighted legends, when viewed under high ambient light, centered mainly around increasing brightness of the display through increasing lamp output or by using lamps of higher brightness ratings. Rather than improving readability this resulted only in producing higher lamp temperatures and/or shorter lamp life. Today's advanced designs of lighted switches and aircraft crew station lighting specifications, however, has brought about a significant change in the concept of what Sunlight Readability is and how it is best achieved.

Rather than "brightness expressed in footlamberts," for years the yardstick by which lighted displays were measured, Sunlight Readability is properly measured by contrast ratios between lighted and unlighted portions of the display. It is this contrast ratio that determines the degree of readability in high ambient lighting. To determine this contrast the lighted display is subjected to a 10,000 foot-candle ambient light and precise brightness measurements, using a photometer under controlled laboratory conditions, are made of the lighted and unlighted portions of the display. The formula for computing the contrast ratio, as defined in MIL-R-28803, is  $C = \frac{B_2 - B_1}{B_1}$  in which C is Contrast Ratio,  $B_2$  is the lighted portion, and  $B_1$  is the unlighted portion.

The overall brightness, as seen by an observer, is the total of the illumination produced by the energized lamps within the display unit, and the illumination produced by the reflection of ambient light off the face of the display. Reduction of this reflected light has a greater effect on improving contrast, and thereby improving readability, than does an equal increase in lamp brightness. To help clarify this statement consider a given display in which measurements resulted in a lighted portion brightness ( $B_2$ ) of 300 and the unlighted portion brightness ( $B_1$ ) of 150. Using the formula given above the contrast would be  $C = \frac{300 - 150}{150}$  or 1. If the lamp brightness is increased by 50 footlamberts the contrast ratio becomes  $C = \frac{350 - 150}{150}$  or 1.33. However, if the reflected illumination is reduced by 50 footlamberts the contrast ratio becomes  $C = \frac{250 - 100}{100}$  or 1.5. Remember reflected illumination is part of  $B_2$  as well as  $B_1$  and both would be reduced by the same amount.

# SERIES 80 LIGHTED PUSHBUTTON SWITCHES

## Table of Contents

Key Features	2
Table of Contents	3
Military Specification	4
Military Part Numbers	4
Sunlight Readable Display Pushbuttons	5-7
Lamp Information	5
Legends, Circuit Diagrams	6-7
Ordering Information	7
Matrix Mounted Switch/Indicators (Models 8M,8CM,8SM)	8-13
Dimensions	9
Termination Receptacles	11-12
Ordering Information	12-13
Switch/Indicator Modules	14-17
Solder, PC, Wire-Wrap-Model 80M	15
Crimp Pin-Model 80CM	16
Indicator Only-Model 80SM	17
Individually Mounted Switch/Indicators	18-22
Switch-Model 87	19
Solder, Wire Wrap-Model 89	20
Crimp Pin-Model 89C	21
Indicator Only-Model 82	22
Accessories	23
Lighting and Switching Controllers	Back Cover

## Full Product Line

StacoSwitch offers a comprehensive line of individually mounted and multi-station matrix mounted sunlight readable display pushbutton switches and indicators. Select 2PDT or 4PDT circuitry, and alternate, momentary, or solenoid held switch action. Matching indicators-only provide exact look-alike displays. Shown in the illustration on the right is a representative selection of a few of the many styles and configurations of units available as standard products, each with legends to customer order.

**A – Series 8SM Indicator Only, Matrix Mount**

**B – Series 80 Sunlight Readable Display Pushbutton.**

**C – Model 82 Indicator**

**D – Series 8M/8CM Switch-Indicator, Matrix Mount.**

**E – Model 89/89C Individual Mount Switch**

**F – Series 87 Switch. 2 PDT or 4 PDT.**

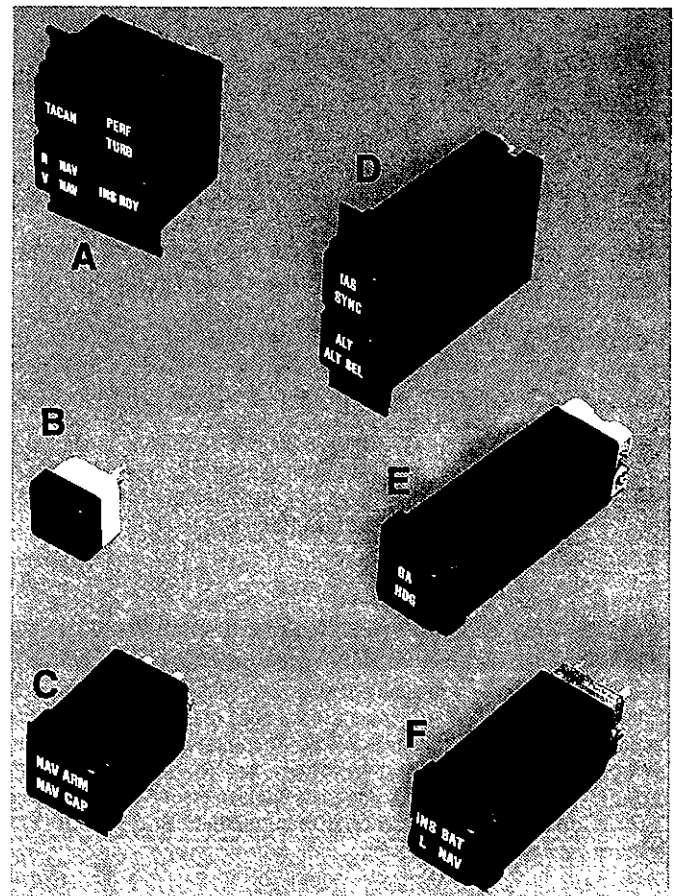

# MIL-SPEC LISTING

## Military Specifications

Various StacoSwitch Switches and accessories have been granted Qualified Product Listing under MIL-S-24317, MIL-S-22885, and MIL-S-8805. In addition these products are designed and manufactured to conform to the following specifications where applicable.

FED-STD-3	Colors: Aeronautical Lighting
MIL-STD-130	Identification and Marking of U.S. Military Property
MIL-STD-202	Test Methods for Electronic and Electrical Component Parts
MIL-STD-411	Air Crew Station Visual Signals
MIL-E-5272	Environmental Testing, Aeronautical
MIL-E-5400	Electronic Equipment, Aircraft
MIL-T-5422	Testing, Environmental, Aircraft Electronic Equipment
MIL-S-8805	Switches, Sensitive and Push, Snap Action, Actuators and Enclosures
MIL-M-18012	Markings for Air Crew Station Displays Design and Configuration of
MIL-C-25050	Colors, Aeronautical Lights and Lighting Equipment
MIL-S-22885	Switches, Pushbutton, Illuminated
MIL-S-24317	Switches, Multistation, Pushbutton

Listed below are the major requirements to which StacoSwitch products are tested.

Temperature, Operating	-55°C to +85°C
Thermal Shock	-55°C to +85°C; per MIL-STD-202, method 107, test condition A
Altitude	Sea level to 70,000 feet (21,341 meters)
Vibration	.06 (1.52) da or 15g's, 10 to 2,000 Hz per MIL-STD-202, method 204, test condition B
Shock	75 g's, 6 millisecond half-sine, per MIL-STD-202, method 202
Sand and Dust	Per MIL-STD-202, method 110, test condition B
Humidity	10 days, with 10 cycles at 90-98 percent relative humidity at 65°C per MIL-STD-202, Method 106
Salt Spray	96 hrs., per MIL-STD-202, method 101, test condition A; with pushbutton installed
Fungus	None of the materials or finishes used in the construction of this switch assembly will support any fungus encountered in tropical climates.
Explosion	These units can be safely operated under load in an explosive atmosphere without danger of explosion per MIL-STD-202, method 109.

## Series 80 Military Part Numbers

The Series 80 Sunlight Readable Display Switches and Indicators, both individual mount and matrix mount, have been granted Mil Spec listing under MIL-S-22885 and MIL-S-24317. The following list is a random selection of Mil Spec Part Numbers and their corresponding STACOSWITCH Part Numbers. Complete cross reference lists of all Series 80 Mil Spec Part Numbers and corresponding STACOSWITCH Part Numbers are available on request.

## Individual Mount Switch/Indicator

MIL-S-22885 Part Number	STACO P/N	MIL-S-22885 Part Number	STACO P/N
M22885/103-001	821	M22885/103-034	89C09A
M22885/103-002	822	M22885/103-035	89C08B
M22885/103-009	8708A	M22885/103-036	89C10B
M22885/103-010	8710A	M22885/103-037	89C07B
M22885/103-011	8707A	M22885/103-038	89C09B
M22885/103-012	8709A	M22885/103-049	8900IS
M22885/103-013	8708B	M22885/103-050	8914IS
M22885/103-014	8710B	M22885/103-053	8908AS
M22885/103-015	8707B	M22885/103-054	8913AS
M22885/103-016	8709B	M22885/103-055	8907AS
M22885/103-027	89C001	M22885/103-056	8912AS
M22885/103-028	89C111	M22885/103-057	8908BS
M22885/103-031	89C08A	M22885/103-058	8913BS
M22885/103-032	89C10A	M22885/103-059	8907BS
M22885/103-033	89C07A	M22885/103-060	8912BS

## Display Screen Pushbuttons

MIL-S-22885 Part Number	STACO P/N	MIL-S-22885 Part Number	STACO P/N
M22885/104-1005	80T2A	M22885/104-1023	80T1C
M22885/104-1006	80T4A	M22885/104-1024	80T3C
M22885/104-1007	80T1A	M22885/104-1029	80T2D
M22885/104-1008	80T3A	M22885/104-1030	80T4D
M22885/104-1013	80T2B	M22885/104-1031	80T1D
M22885/104-1014	80T4B	M22885/104-1032	80T3D
M22885/104-1015	80T1B	M22885/104-1037	80T2E
M22885/104-1016	80T3B	M22885/104-1038	80T4E
M22885/104-1021	80T2C	M22885/104-1039	80T1E
M22885/104-1022	80T4C	M22885/104-1040	80T3E

## Switch/Indicator Modules - Matrix Mount

MIL-S-22885 Part Number	STACO P/N	MIL-S-22885 Part Number	STACO P/N
M22885/105-001	80SM1	M22885/105-012	80M10B
M22885/105-002	80SM2	M22885/105-013	80M07B
M22885/105-003	80M00I	M22885/105-014	80M09B
M22885/105-004	80M11I	M22885/105-015	80CM08A
M22885/105-005	80CM00I	M22885/105-016	80CM10A
M22885/105-006	80CM11I	M22885/105-017	80CM07A
M22885/105-007	80M08A	M22885/105-018	80CM09A
M22885/105-008	80M10A	M22885/105-019	80CM08B
M22885/105-009	80M07A	M22885/105-020	80CM10B
M22885/105-010	80M09A	M22885/105-021	80CM07B
M22885/105-011	80M08B	M22885/105-022	80CM09B

## Matrix Housing

MIL-S-24317 Part Number	STACO P/N
M24317/12-XXX	Various

NOTE: The QPL part numbers listed above are representative but by no means are they the complete list. Refer to QPL documents for complete listings, or contact STACOSWITCH for a complete cross reference list of all Series 80 Mil Spec Part Numbers and corresponding STACOSWITCH Part Numbers.

# SERIES 80 SUNLIGHT READABLE DISPLAY PUSHBUTTONS

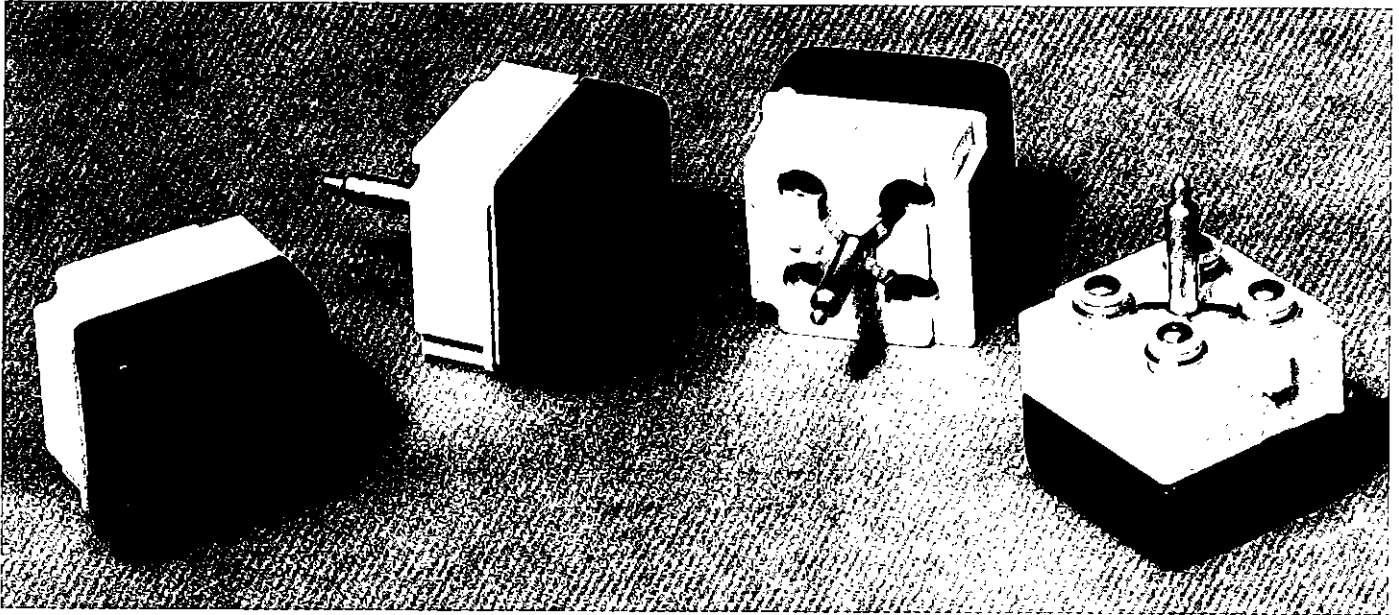

Series 80 Illuminated Display Pushbuttons are manufactured to meet the sunlight readability and environmental requirements of MIL-S-22885. Designed to operate with four T-1 size midget flange base lamps with .15 MSCP, the pushbuttons mate with Models 87,89, and 89C Switches, Model 82 Indicator, and the Switch/Indicator Modules of Series 8M, 8SM, and 8CM Matrix Mounted Assemblies. Pushbuttons, lamps, and switches or indicators each have their own part number, and each must be ordered separately. Once the description of parts is determined a factory assigned assembly number can be given where desired.

## Captive Pushbuttons

Pushbutton is available as a standard option, except for solenoid held switch units, with bail feature that allows the pushbutton to be removed from the front of the panel and yet retain it to the matching switch body. This eliminates possible insertion of the wrong pushbutton. In the event the pushbutton is to be removed entirely the bail can be quickly reengaged for reinstallation.

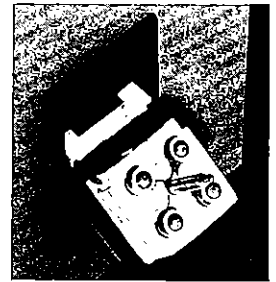

## Lamp Circuitry

Pushbuttons are available with either common lamp ground (CLG) for all four lamps, or with a split lamp ground (SLG) where lamps 1 and 4 are common and lamps 2 and 3 are common. For a vertical SLG 2-way split display mount switch/Indicator 90° with the latch lever at bottom of the pushbutton, as shown below. For horizontal SLG 2-way split display rotate switch/indicator 90° and mount with the latch lever to the left of the pushbutton. CLG switch/indicators are always mounted with latch lever at bottom, regardless of style of display.

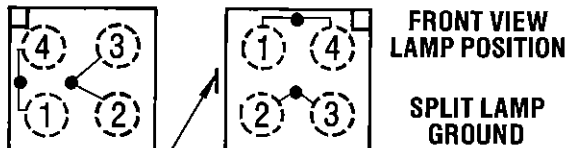

Ref. Switch/Indicator latch lever position with Pushbutton Display Style A, B, C, D or E.

Ref. Switch/Indicator latch lever position with Pushbutton Display Style F, G or H.

## Lamps

T-1 midget flange based incandescent lamps fit all StacoSwitch Series 80 Sunlight Readable Display Pushbuttons. Lamps are not included with pushbuttons or switches and must be ordered separately. Lamps with MSCP of .15 must be used if correct degree of sunlight readability is to be achieved. Lamps listed below are available from StacoSwitch. These and other voltages are also available from local distributors.

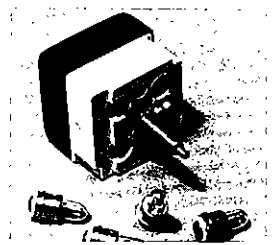

Lamp specifications are published by the lamp manufacturer and StacoSwitch does not warrant lamp performance as specified.

PART NUMBER	MILITARY PART NUMBER	DESIGN VOLTS	DESIGN AMPS	M.S.C.P.	R.A.L.L.
3071		5	.06	.15	6,500
718	24515-718	5	.115	.15	40,000
6839	3338-6839	28	.024	.15	16,000

NOTE: Available from Stacoswitch stock  
M.S.C.P. = Mean Spherical Candle Power  
R.A.L.L. = Rated Average Lab. Life (Hours)

# SERIES 80 SUNLIGHT READABLE DISPLAY PUSHBUTTONS

## Circuit Diagrams

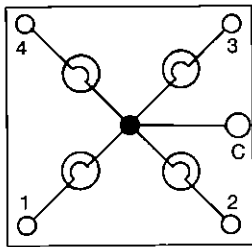

### FRONT VIEW LAMP POSITION

Circuit diagrams illustrate lamp positions as viewed from the front of the pushbutton display screen in correlation to lamp terminal identification numbers on the rear of the switch/indicator.

Common Lamp Ground (CLG)  
All Display Styles.

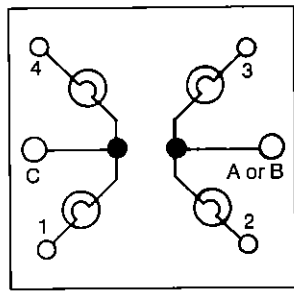

Split Lamp Ground (SLG)  
Display Styles F, G, and H.

Ref. Latch Lever position  
when switch/indicator is installed.

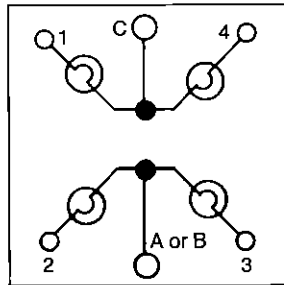

Split Lamp Ground (SLG)  
Display Styles A, B, C, D, and E.

## Pushbutton Models

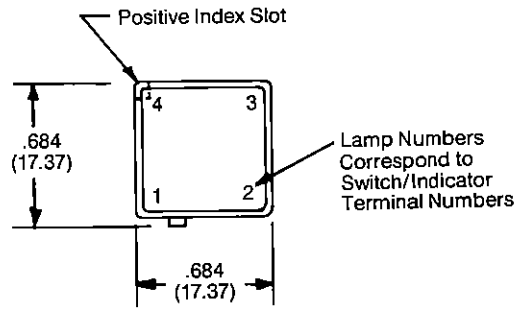

## Noncaptive Pushbuttons

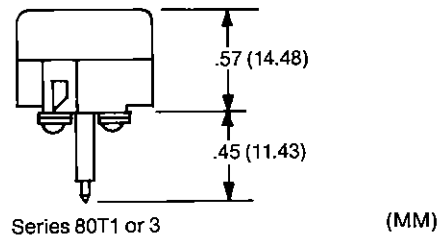

## Pushbutton Type - Table 1

Refer to ordering information

### MODEL

T1  
T2\*  
T3  
T4\*

### DESCRIPTION

NON-CAPTIVE, CLG  
CAPTIVE, CLG  
NON-CAPTIVE, SLG  
CAPTIVE, SLG

CLG = Common Lamp Ground SLG = Split Lamp Ground

\* Not available for, nor compatible with solenoid held "D" type switches or switch modules.

## Captive Pushbuttons

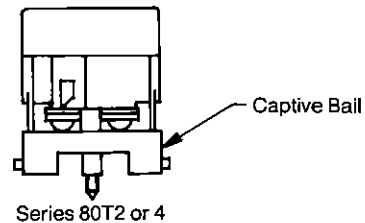

## Display Styles and Legend Areas - Table 2

DISPLAY STYLE CODE	LEGEND AREA	CHARACTERS/LINE/COL** MAX. NO.				COL**/LINES/AREA MAX. NO.					
		CHAR. HGT.	LEGEND AREA				CHAR. HGT.	LEGEND AREA			
			1	2	3	4		1	2	3	4
A	1	.100*	8	—	—	—	.100*	4	—	—	—
		.125*	6	—	—	—	.125*	3	—	—	—
B	1 2	.100*	8	8	—	—	.100*	2	2	—	—
		.125*	6	6	—	—	.125*	1	1	—	—
C	1 2 3	.100*	3	3	8	—	.100*	2	2	2	—
		.125*	3	3	6	—	.125*	1	1	1	—
D	1 2 3	.100*	8	3	3	—	.100*	2	2	2	—
		.125*	6	3	3	—	.125*	1	1	1	—
E	1 2 3 4	.100*	3	3	3	3	.100*	2	2	2	2
		.125*	3	3	3	3	.125*	1	1	1	1
F	1 2	.100*	5**	5**	—	—	.100*	2**	2**	—	—
		.125*	4**	4**	—	—	.125*	2**	2**	—	—
G	1 3 2	.100*	3	3	5**	—	.100*	2	2	2**	—
		.125*	3	3	4**	—	.125*	1	1	2**	—
H	1 2 3	.100*	5**	3	3	—	.100*	2**	2	2	—
		.125*	4**	3	3	—	.125*	2**	1	1	—

# SERIES 80 SUNLIGHT READABLE DISPLAY PUSHBUTTONS

## Sunlight Readable Colors - Table 3

Refer to Ordering Information		Readability	
Color Code	Color	(Relative Values)	
BX	Blue	Fair	
GX	Green	Very Good	
RX	Red	Very Good	
WX	White	Excellent	
AX	Amber	Excellent	
YX	Yellow	Excellent	

Colors are in accordance with MIL-22885/104

## Legends

Standard legend heights are .100" (2.54mm) and .125" (3.18mm). Other legend heights are available by special order. .125" character height is recommended for optimum sunlight readability. The character format for alpha- numerics is Alternate Gothic No. 2 (sans serif)

## Specifications

**MECHANICAL:** A. Weight, including lamps: .011 lbs. (4.99 gms.)  
 B. Faceplate will withstand 25 pound (11.35 Kg) distributed load.  
 C. Relamping accomplished without use of tools

**ELECTRICAL:** A. Dielectric Strength  
 Sea Level 1,056 VRMS  
 70,000 feet 450 VRMS  
 B. Insulation Resistance 1,000 MEGOHMS @ 500VDC

**ENVIRONMENTAL:** Meets or exceeds applicable Military Specification MIL-S-22885 for salt spray, moisture resistance, thermal shock, vibration, and sand, dust and fungus resistance.

## Ordering Information

80 T1 B RX GX XX XX 1 (Trim) (Engage) (x) (x) Typical Part Number:

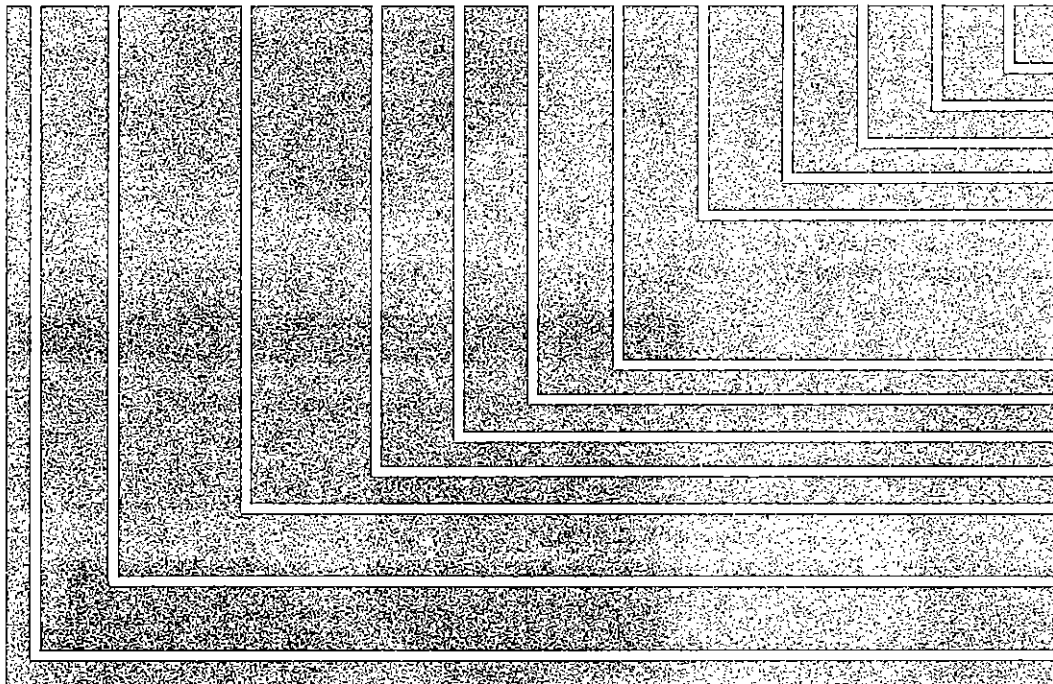

Legend - See Table 2

- Area No. 4
- Area No. 3
- Area No. 2
- Area No. 1

Character Height - See Table 2

- 1 - .125 (3.18mm)
- 2 - .100 (2.54mm)

Legend Color - See Table 3

- Area No. 4
- Area No. 3
- Area No. 2
- Area No. 1

Display Style - Table 2

- A, B, C, D, E, F, G, or H

Pushbutton Model - See Table 1

- T1, T2, T3, or T4

Series 80 Pushbutton

Note: Enclose legend for each area in parenthesis. Use an X for legend areas not used. Separate lines in each area by a semi-colon.

Example: (AUTO; POWER) (MANUAL; POWER) (X) (X)

Prefix "R" in front of model number (R80) denotes RFI/EMI shielded. Omit for non-RFI.

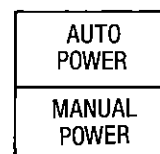

# MATRIX MOUNTED SERIES 80 SWITCH/INDICATORS

## Choice of Mounting Styles

Matrix mounted switch/indicator assemblies are a total switching system neatly packaged in a single integrated housing. Made up of anywhere from one to one hundred stations, this compact package groups all switching functions in one small area. Saves precious panel space. The housings are modular units custom built to the desired number of stations. Constructed of 3/4" square aluminum tubes, the lightweight, yet rugged housing actually strengthens the panel, regardless of cutout size. Switch/indicator housing extends only 2.46", plus termination, behind the panel; the indicator only housing extends only 1.44", including the terminations.

## Front Panel Servicing

Plug-in switch and indicator modules can be replaced from front of panel without touching the panel wiring. Jackscrew retainer facilitates insertion and removal of the modules. The plug-in Sunlight Readable Display Pushbutton can also be relamped from front of the panel without use of tools.

## Models 8M, 8CM Matrix System Housing

**TERMINATION OPTIONS** – The Model 8M Matrix Housings are supplied with choice of solder, PC, or wire wrap terminals. Mating switch and indicator modules, Model 80M, are used with any of the three terminals. Termination receptacle can be wired in the housing or may be pre-wired and installed later in the housing by inserting from the back. No special tools are required. Housing, except for length, is identical to StacoSwitch's QPL Series 40, Model 1M Matrix Housings. Switches and indicators may be mixed in same housing.

The Model 8CM Matrix Housings are equipped with termination receptacles that accept QPL M39029/1-101 Male Crimp Pins. Model 80CM Switch/Indicator Modules are used with the Model 8CM Housing. Mating retainer holes in termination receptacle and female connector holes in switch/indicator module securely hold male crimp pin and maintain proper electrical contact even under conditions of extreme shock and vibration. Wiring time is cut to an absolute minimum. Solder or wire wrap connection are completely eliminated.

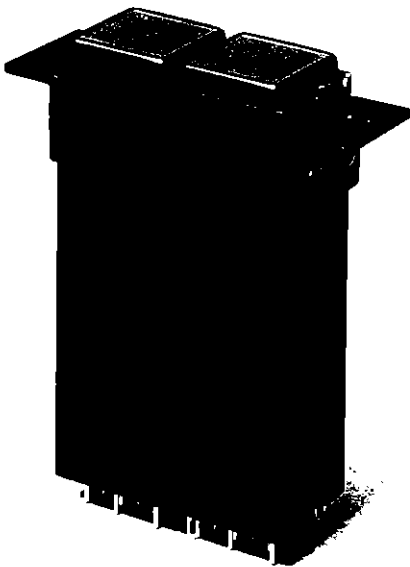

Select either rear mounting flanges or front mounting dress bezels. Rear mount flange "set-back" is custom made to accommodate desired panel thickness. Slotted holes on flanges simplify installation. The modern looking front mounting dress bezel is made of attractive extruded aluminum in choice of clear satin finish or black anodize finish. Custom anodized colors are available on special orders. Mounting cleats, inserted from rear of panel, tighten against back of panel securely fastening entire housing and bezel assembly in place.

## Model 8SM Indicator Only Matrix Housing

**SHORT MATRIX** – This compact unit extends only 1.44" behind the panel. Group all status indicators in one convenient area for ease of data identification. Custom assembled to include any number of stations required, you can get more Sunlight Readable Indicators into one small area with this "space saver". Model 80SM Indicator Modules are used with the Series 8SM Matrix Housing.

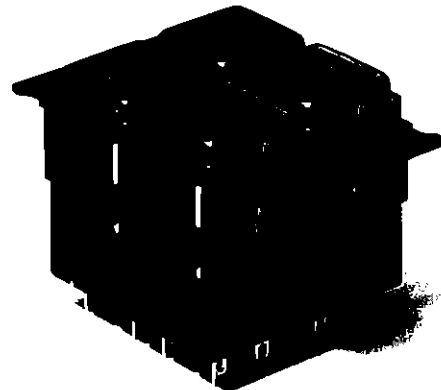

## Custom Wired Matrix Housing

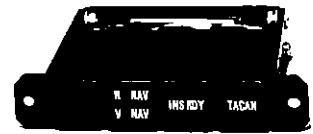
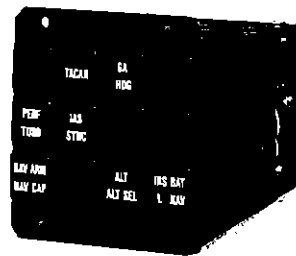

Complete plug-in matrix assemblies with wired connectors are available on special order. Units shown above have standard pin connectors attached to the matrix housing with special brackets. Wiring from switch/indicator station termination receptacles to the pin connector is to customer's schematic diagrams. Units are used in the United States Coast Guard's Medium Range Surveillance Aircraft.

# PANEL MOUNT DIMENSIONS

## Rear Mount Flange Models 8M, 8CM, and 8SM Dimensions

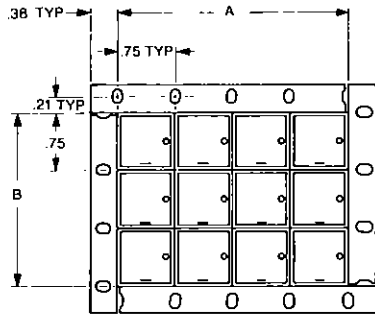

4 FLANGES

HORIZONTAL FLANGES

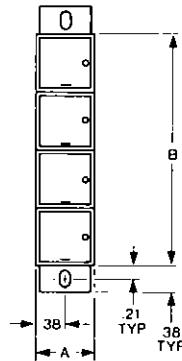

VERTICAL FLANGES

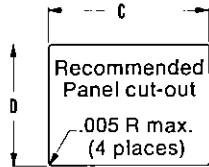
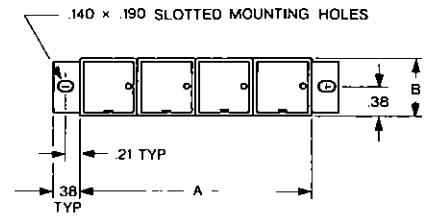

**RECOMMENDED PANEL MOUNTING DETAIL**

Number of Units on Side	Dim. A or B $\pm .015$	Cut-Out Dimension C or D $+.030$ $-.000$
1	.755	.775
2	1.510	1.530
3	2.265	2.285
4	3.020	3.040
5	3.775	3.795
N	.755xN	.755xN $+.02$

## Front Mount Dress Bezel Models 8M, 8CM, and 8SM Dimensions

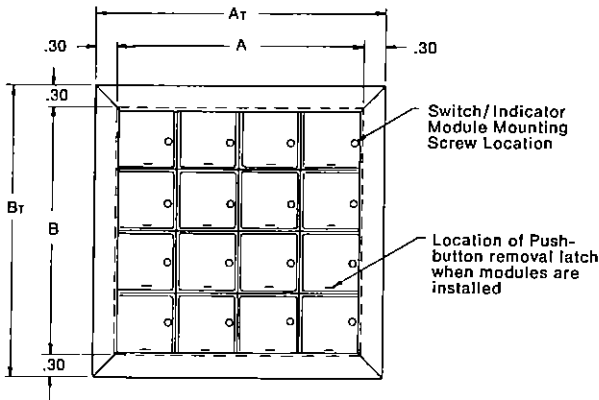

**RECOMMENDED PANEL MOUNTING DETAIL**

Number of Units Per Side	Matrix Dimension "A" or "B" $\pm .015$	Cut-Out Dimension "C" or "D" $+.030$ $-.000$	"Ar" or "Br" Ref. Overall Flange
1	.755	1.124	1.352
2	1.510	1.879	2.107
3	2.265	2.634	2.862
4	3.020	3.389	3.617
5	3.775	4.144	4.372
6	4.530	4.899	5.127
"N"	.755 x "N"	Dim. "A" or "B" Plus .369	Dim. "Ar" or "Br" Plus .597

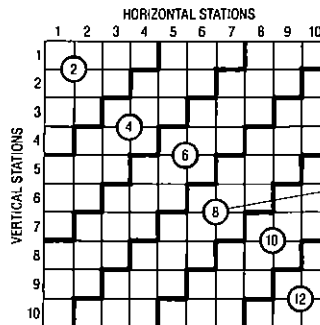
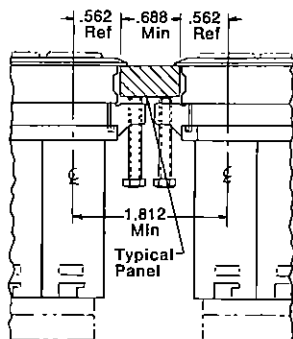
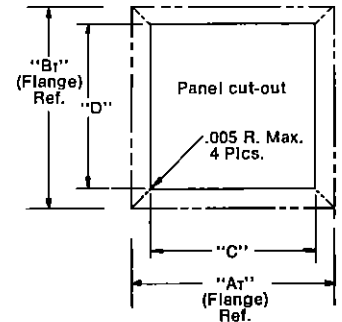

Number of mounting cleats supplied, per size of matrix housing.

Quantity of mounting cleats

Cleats to be equally spaced around matrix housing bezel. Self-locking screws are secured at 7 inch pounds max. CAUTION—do not exceed recommended torque.

# MATRIX HOUSING DIMENSIONS

## Model 8M Dimensions

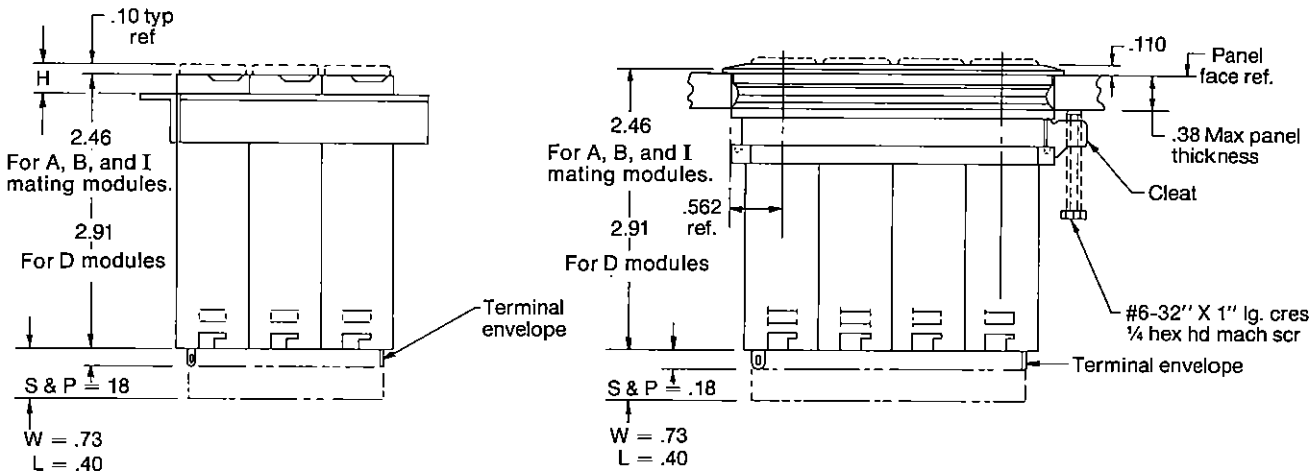

## Model 8CM Dimensions

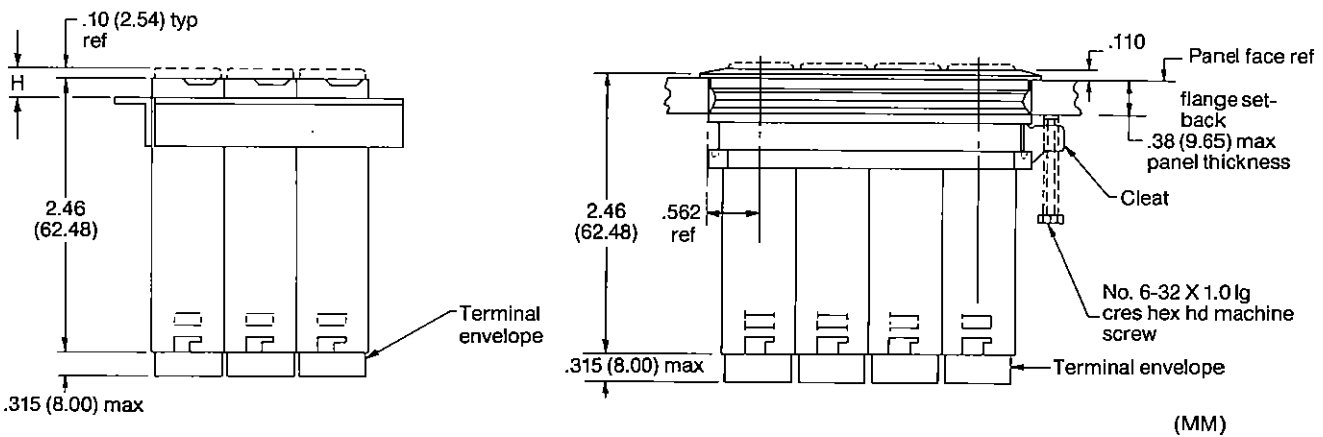

## Model 8SM Dimensions

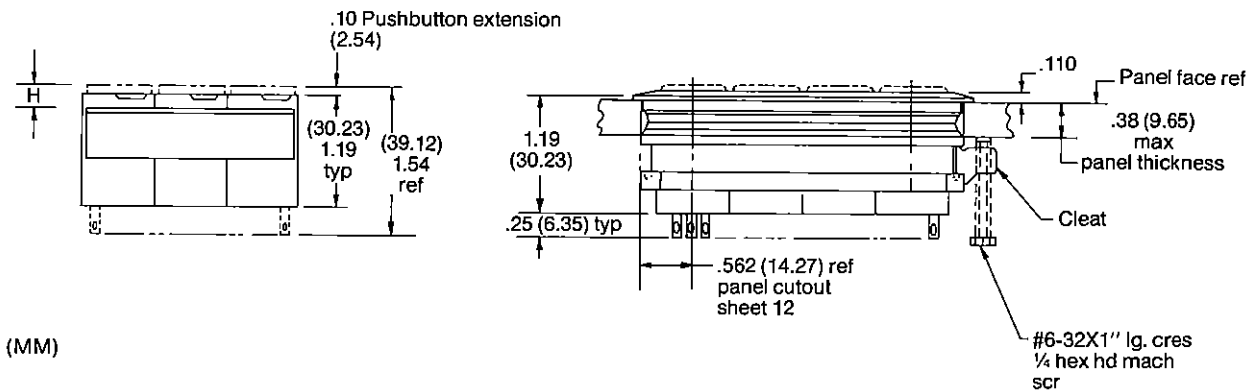

# MODEL 8M MATRIX HOUSING TERMINATION RECEPTACLES

Termination receptacles, solder, PC, or wire wrap, are normally furnished as part of the Matrix Housing. One receptacle is installed at rear of each matrix channel or station.

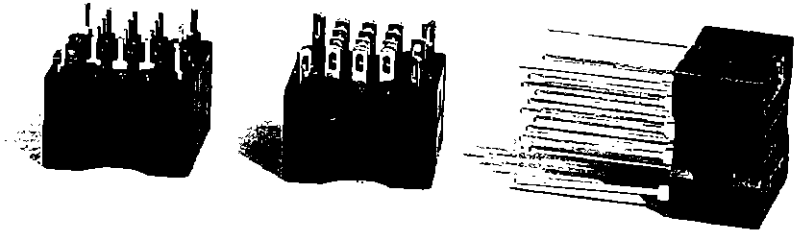

**Style P**  
Printed Circuit Terminal

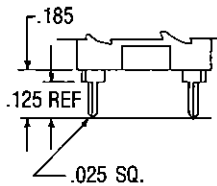

**Style S**  
Solder Terminal

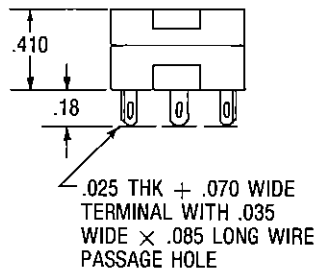

**Style W/L**  
Wire Wrap Terminal

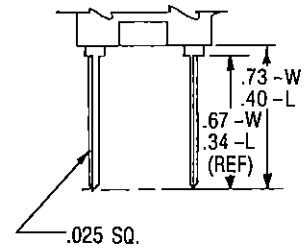

## Printed Circuit Board Layout

PC board hole layout, shown in drawings below, mate with PC terminations on the Style "P" termination receptacle. .036" dia. holes viewed from component side of board. (Tolerances  $\pm .005$ " to be non-cumulative.)

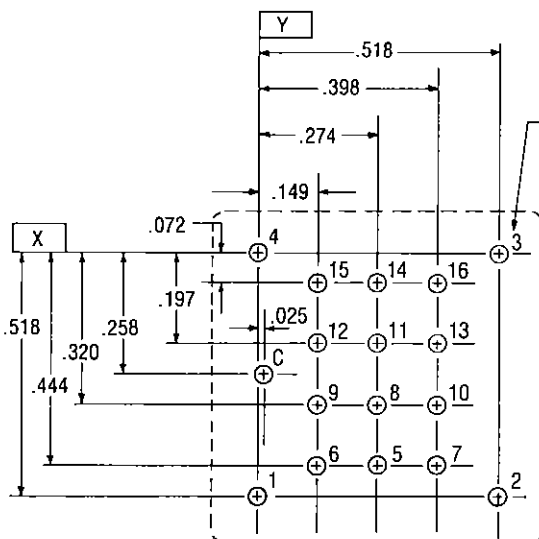

NUMBERS AND LETTERS DENOTE LOCATION OF RECEPTACLE TERMINALS AS VIEWED FROM FRONT OF SWITCH

DOTTED LINE INDICATES AREA OF RECEPTACLE BODY

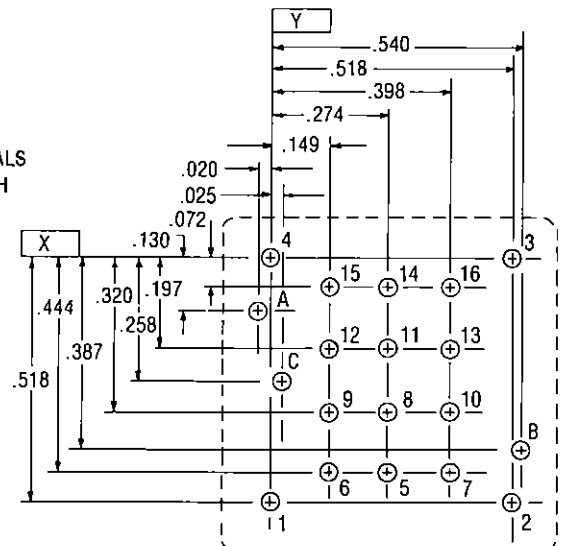

# TERMINAL LAYOUT

## Model 8M Matrix Receptacle

Termination receptacle used in all stations of Model 80 Matrix Housings. Mates with alternate or momentary switch module and indicator only module, other common or split lamp ground. Also mates with solenoid held switch modules. Check schematic diagrams of switch/indicator modules used to determine receptacle terminations to be wired. See pages 15 through 22.

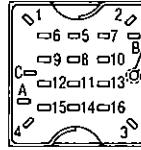

Mounting screw location for Switch/Indicator module.

## Model 8CM Matrix Receptacle

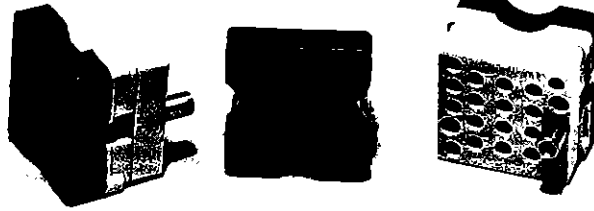
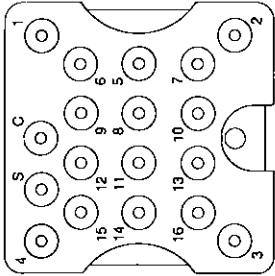

Receptacles used in all stations regardless of type of switch or indicator module.

## Ordering Information For Systems

When ordering complete systems . . . matrix housing, switch/indicator modules, and pushbuttons . . . an Assembly Part Number can be assigned by the factory to cover the complete system. Each Channel or station within the matrix must be identified by a specific switch or indicator module and a Pushbutton Display Screen. Each station in the matrix is identified by a digit-dash-digit, called a Location Code.

The first digit in the Location Code identifies the horizontal row and the second digit identifies the vertical column. In the example 3-4 the third row down and the fourth column to the right. Location 1-1 will always be top left as viewed by the OPERATOR. Pre-numbered work sheets are available from the factory on request.

TO SPECIFY A COMPLETE ASSEMBLED MATRIX SYSTEM FILL IN A CHART AS SHOWN BELOW:

LOCATION	SWITCH/ INDICATOR MODULE PN:	PUSHBUTTON DISPLAY SCREEN PN:
1-1		
1-2		
1-3		
3-2		
3-3		
3-4		

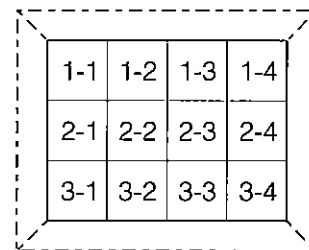

# ORDERING INFORMATION-MATRIX HOUSINGS

## Model 8CM - Crimp Pin Terminations and 8SM - Indicator Only

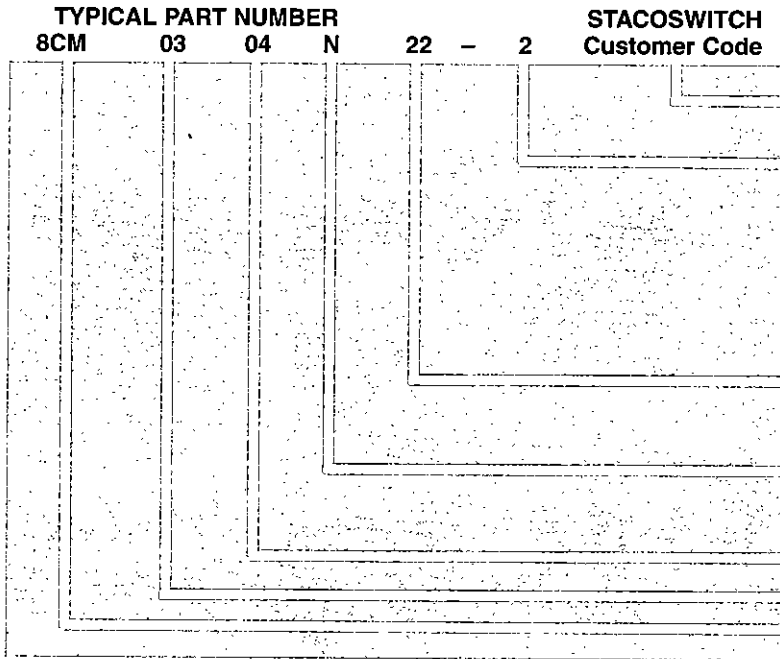

### ASSEMBLY PART NUMBER CODE

Assigned by STACOSWITCH to define specific detail of requirements of assemblies

- 1 = Horizontal flange, rear mount
- 2 = Vertical flange, rear mount
- 3 = Four flange configuration, rear mount
- X = No flange required
- 5 = Bezel, front mount, black anodize
- 7 = Bezel, front mount, clear anodize
- 9 = Bezel, front mount, RFI/EMI, irridite
- C = Bezel, front mount, colored finish

Flange set back in two-place decimal increments. (Dimension "H"; see page 10.) .110" fixed for front mount bezel. Use "11" as standard.

Shield options: N = Non-shielded, black anodize finish. R = RFI/EMI shielded, irridite finish. (Dress bezel, if applicable, will also require RFI/EMI shielding)

Number of Vertical stations

Number of Horizontal stations

Matrix Model: 8CM, Crimp Pin Terminations

8SM, Indicator only, solder terminals/spade lugs

## Model 8M - Solder, WireWrap, or PC

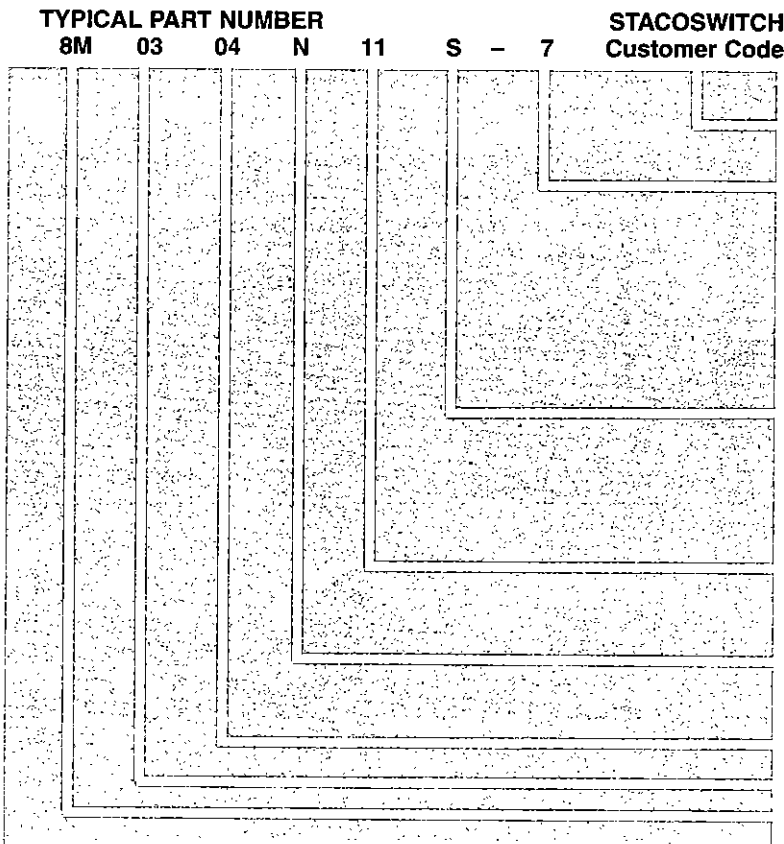

### ASSEMBLY PART NUMBER CODE

Assigned by STACOSWITCH to define specific detail of requirements of assemblies

- 1 = Horizontal flange, rear mount
- 2 = Vertical flange, rear mount
- 3 = Four flange configuration, rear mount
- X = No flange required
- 5 = Bezel, front mount, black anodize
- 7 = Bezel, front mount, clear anodize
- 9 = Bezel, front mount, RFI/EMI, irridite
- C = Bezel, front mount, colored finish

Receptacle terminals:

- P = PC board type
- S = Solder lug type
- W = Wire Wrap type - .73 length
- L = Wire Wrap type - .40 length

Flange set back in two-place decimal increments. (Dimension "H"; see page 10.) .110" fixed for front mount bezel. Use "11" as standard.

Shield options: N = Non-shielded, black anodize finish. R = RFI/EMI shielded, irridite finish. (Dress bezel, if applicable, will also require RFI/EMI shielding)

Number of Vertical stations

Number of Horizontal stations

Matrix Model: 8M

Note: When specifying housing assemblies that will accommodate both common lamp and/or split lamp grounds, the intended location in the matrix assembly must be designated.

# SWITCH INDICATOR MODULES FOR MATRIX HOUSING

The dependable and long proven Stacoswitch snap action switch mechanism is used in both the Model 80M and 80CM Modules. With the exception of the shorter latch lever, the 80M Switch/Indicator Module is identical to Stacoswitch's QPL Model 40M Modules, and the Model 80CM to the Model 401M Modules. Design qualifications, premium grade materials, and precious metal contacts assure reliable, trouble-free operation. Careful workmanship and thorough testing mean highest quality switches every time. Providing 4-lamp capability with 2PDT or 4PDT circuitry, the plug-in modules offer a wide switching range. Positive mating of module and termination receptacle is provided by a retainer jackscrew which also facilitates insertion and removal of the module.

The short Model 80SM Indicator-Only Module provides the same high quality, 4-lamp capability in a compact, space-saver warning light. Common or split lamp grounds are available on all three models, 80M, 80CM, and 80SM.

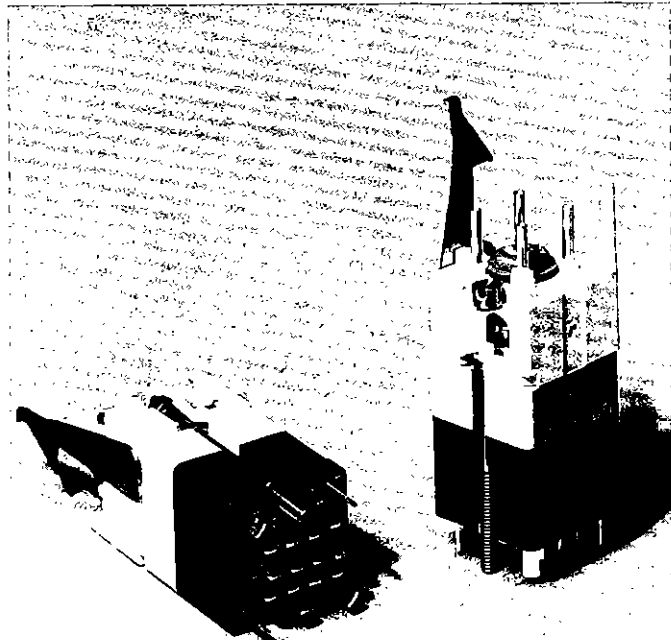

## Switch/Indicator Module - Model 80M

The Model 80M Switch/Indicator Module is used with the Series 8M Matrix Housing. The modules mate with the termination receptacle, solder, PC, or wire wrap, at the rear of each matrix station. Modules are available as alternate or momentary action, 2PDT or 4PDT, and as indicator only, enabling switches and indicators to be intermixed in the same matrix housing. Modules can be serviced from front of panel without touching behind panel wiring. Pushbuttons can be relamped from front of panel without using tools.

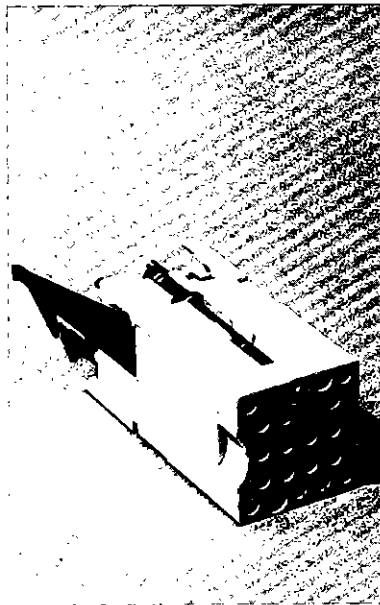

## Switch/Indicator Modules - Model 80CM

The Model 80CM Switch/Indicator Module is used in the Series 8CM Matrix Housing. Female connectors in modules mate with retainer holes in termination receptacle. Crimp pin connectors are securely held and maintain proper electrical contact, even under conditions of extreme shock and vibration. Modules are available as alternate or momentary action, 2PDT or 4PDT, and as indicator only, enabling switches and indicators to be intermixed in the same matrix housing. Both the Switch/Indicator Modules and the Sunlight Readable Display Pushbutton can be serviced from the front of the panel without touching the behind-the-panel wiring. Pushbuttons can be relamped without use of tools.

## Indicator Only Modules - Model 80SM

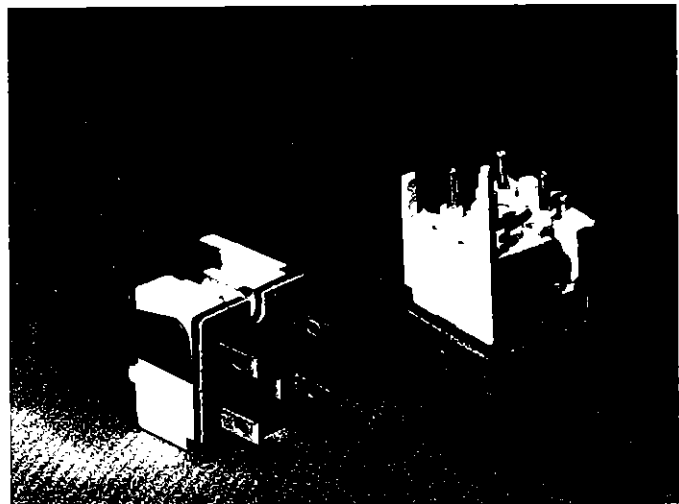

The Model 80SM Indicator-Only Module is used in the Series 8SM Matrix Housing. 4-lamp capability in a compact package. Available with either common or split lamp ground. Solder terminals only. Provides same front panel relamping of Sunlight Readable Display Pushbuttons as do the switches.

# SWITCH/INDICATOR MODULE - MODEL 80M

## Dimensions

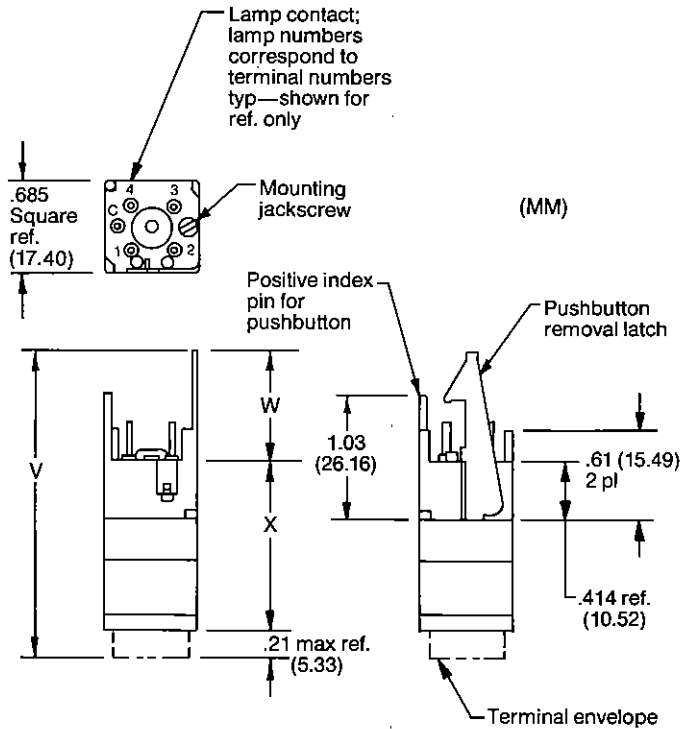

HEIGHT DIMENSIONS

Dim.	"A", "B", "I"	"D"
V	2.25 (57.15)	2.51 (63.75)
W	.80 (20.32)	.64 (16.30)
X	1.24 (31.50)	1.87 (47.50)

## Specifications

- MECHANICAL:**
- A. Actuation Force,  $3.5 \pm 1.0$  Pounds ( $1.59 \pm .454$ kgms)
  - B. Actuation Travel, 200 (5.08) Maximum
  - C. Weight, .032 Pound (14.53gms.)  $\pm 10\%$
  - D. Life, 50,000 Mechanical Cycles
- ELECTRICAL:**
- A. Life at rated load, 25,000 Cycles, minimum
  - B. Contact Load Rating
 

28 VDC	115 VAC
Resistive	2 Amps
Inductive	1 Amps
Lamp	.75 Amps
Logic Level	(5V, 10 Milliamps)
  - C. Contact Resistance
 

Switch	Lamp
Initial	.025 Ohm, Max. 1.0 Ohm, Max.
  - D. Dielectric Strength
 

Sea Level, 1,056 VRMS
70,000 Feet, 450 VRMS
  - E. Insulation Resistance, 1,000 Megohms @ 500 VDC
- ENVIRONMENTAL:** Applicable military specification MIL-S-22885 Salt Spray, Moisture Resistance, Thermal Shock, Vibration, Sand and Dust and Fungus Resistance.

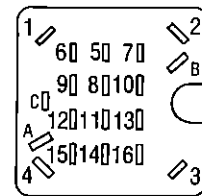

Terminal Arrangement

## Schematics

### Schematic Diagrams

4PDT switch schematic shown. For 2PDT omit terminals 8-13. For indicator only omit terminals 5-16. With momentary action switch, switch terminals 6, 9, 12, and 15 are normally closed. Split lamp ground is not available with solenoid held switch.

#### Common Lamp Ground

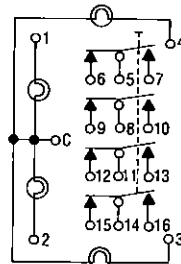

#### Split Lamp Ground

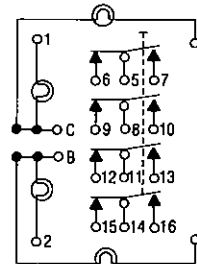

#### Solenoid Held

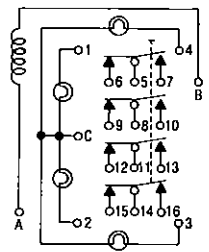

## Ordering Information

80M 08 A

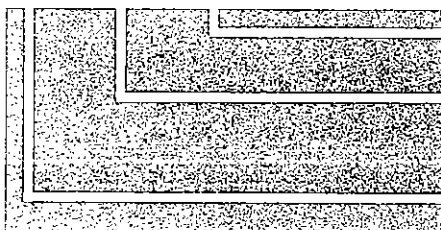

### TYPICAL PART NUMBER

Switch Operation  
A = Momentary, B = Alternate, I = Indicator Only D = Solenoid Held

Circuit Configuration  
07 = 2PDT/CLG, 08 = 4PDT/CLG, 00 = Indicator Only/CLG  
09 = 2PDT/SLG, 10 = 4PDT/SLG, 11 = Indicator Only/SLG

Model Number: 80M SWITCH/INDICATOR

CLG = Common Lamp Ground  
SLG = Split Lamp Ground

# SWITCH/INDICATOR MODULE - MODEL 80CM

## Dimensions

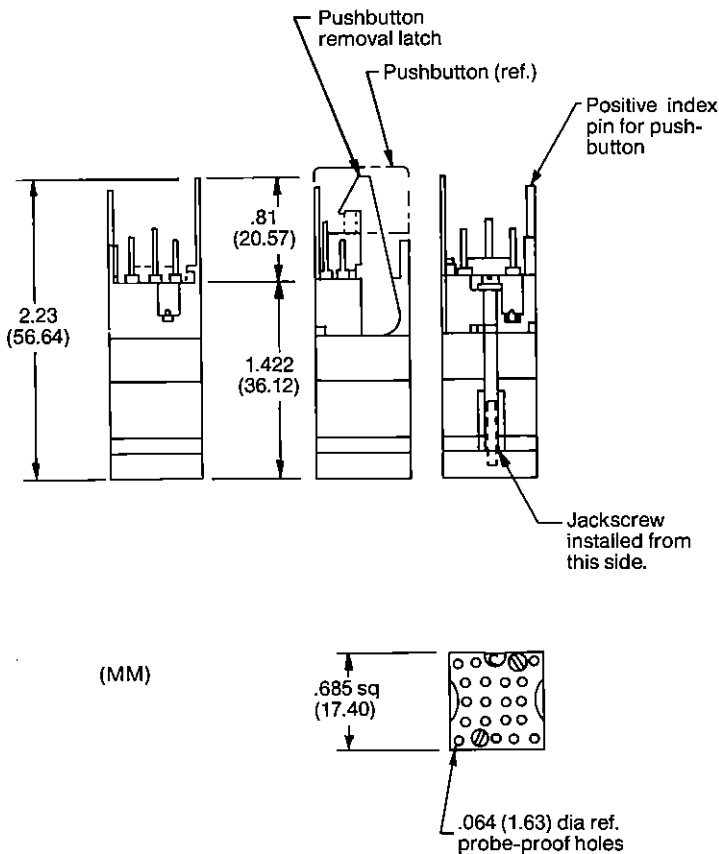

## Specifications

- MECHANICAL:**
- A. Actuation Force,  $3.5 \pm 1.0$  Pounds ( $1.59 \pm .45$ kgms)
  - B. Actuation Travel, .200 (5.08) Maximum
  - C. Weight, .032 Pound (14.53gms.)  $\pm 10\%$
  - D. Life, 50,000 Mechanical Cycles
  - E. Wire Termination, Insertion and Removal Force as defined in MS3197.
- ELECTRICAL:**
- A. Life at rated load, 25,000 Cycles, minimum
  - B. Contact Load Rating 28 VDC 115 VAC
    - Resistive 2 Amps 2 Amps
    - Inductive 1 Amp 1 Amp
    - Lamp .75 Amp 1 Amp
  - Dry Circuit, 10 Microamps  
10 Millivolts to 28VDC
  - C. Contact Resistance Switch Lamp  
Initial .025 Ohm, Max. 1.0 Ohm, Max.
  - D. Dielectric Strength  
Sea Level, 1,056 VRMS  
70,000 Feet, 450 VRMS
  - E. Insulation Resistance, 1,000 Megaohms @ 500 VDC

**ENVIRONMENTAL:** Applicable military specification MIL-S-22885 Salt Spray, Moisture Resistance, Thermal Shock, Vibration, Sand and Dust and Fungus Resistance.

Note: Mates with M39029/1-101 Crimp Pins.

## Schematic

4PDT pushbutton switch schematic shown. For 2PDT omit terminals 8-13. For indicator only omit terminals 5-16. With momentary action switch terminals 6, 9, 12, and 15 are normally closed.

### Common Lamp Ground

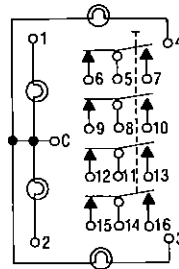

### Split Lamp Ground

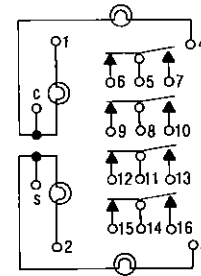

## Ordering Information

80CM 08 A

### TYPICAL PART NUMBER

#### Switch Operation

A = Momentary, B = Alternate, I = Indicator Only D = Solenoid Held

#### Circuit Configuration

07 = 2PDT/CLG, 08 = 4PDT/CLG, 00 = Indicator Only/CLG  
09 = 2PDT/SLG, 10 = 4PDT/SLG, 11 = Indicator Only/SLG

Model Number: 80CM Switch/Indicator, Crimp Pin

CLG = Common Lamp Ground  
SLG = Split Lamp Ground

NOTE: Solenoid Held "D" version not available in Model 80CM Module

# INDICATOR MODULE - MODEL 80SM

## Dimensions

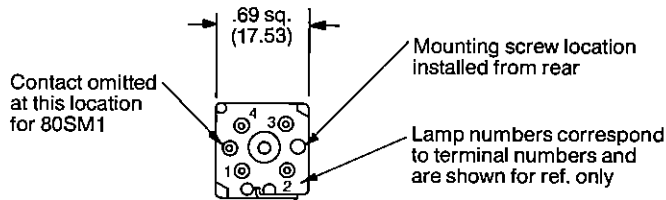

Positive index post for pushbutton orientation  
Latch lever pushbutton retention

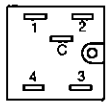
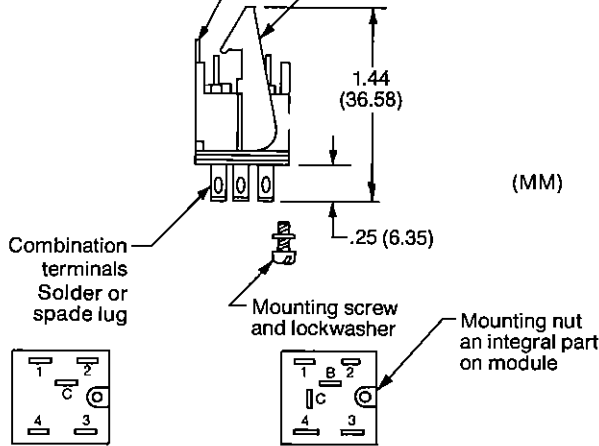

Terminal Arrangement

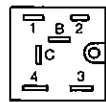

Split Lamp Ground

Common Lamp Ground

## Specifications

**MECHANICAL:** A. Weight, .017 lbs (8 gms)  $\pm 10\%$   
B. Life, 1000 hrs. (minimum)

**ELECTRICAL:** A. Lamp Circuit Resistance, 0.5 Ohm max.  
B. Dielectric, 1056 VRMS  
C. Insulation Resistance, 500 Megohm

**ENVIRONMENTAL:** Applicable military specification MIL-S-22885 Salt Spray, Moisture Resistance, Thermal Shock, Vibration, Sand and Dust and Fungus Resistance.

## Schematic

### Common Lamp Ground

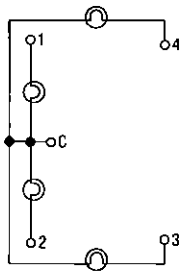

### Split Lamp Ground

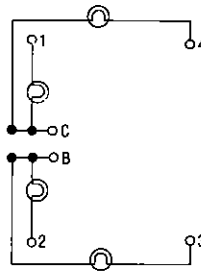

## Ordering Information

80SM 2

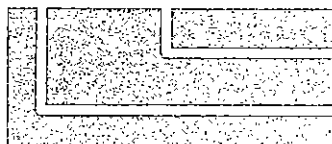

### TYPICAL PART NUMBER

1 = Common Lamp Ground (CLG)  
2 = Split Lamp Ground (SLG)  
Model Number: 80SM, Short Matrix Indicator Module

# INDIVIDUAL MOUNT SWITCH/INDICATOR MODULES- MODELS 87,89,82

## Proven Dependability

Series 80 Sunlight Readable Display Switches and Indicators are ruggedly dependable, long proven components. The same switching assembly used in Stacoswitch's QPL Series 40 Switch is also used in the Series 80 Switches. They have a long history of successful service on high performance aircraft, naval shipboard applications, ground control equipment, and critical industrial and medical applications demanding maximum performance. Contact materials are high conductivity precious metal alloys, gold plated for optimum contact reliability.

## Easy Installation and Relamping

Series 80 Switch/Indicators mount in a .750" square panel opening. The switch or indicator housing is simply inserted into the mounting hole from the front of the panel and the mounting sleeve is then slid into the housing from the front of the panel and the mounting sleeve is then slid onto the housing from the rear of the panel. Housings can be installed with the spacer collar either in front or behind the mounting panel. This allows the units to be mounted flush to the panel or extended for use with an additional overlay panel. Tightening the retaining screw securely clamps the switch or indicator assembly to the panel. All lamp and switch terminations are on the same plane for ease of wiring. Pushbuttons can be relamped from front of panel without use of tools. Pushbuttons must be ordered separately. See pages 5 through 7 for pushbutton ordering information.

## Solder Terminals Switch Model 87



This very versatile switch is available in momentary action for trigger functions, or alternate action for maintained "on and off" functions. Choice of 2PDT or 4PDT circuitry, with a switching range from 2 amps resistive power down to 10 micro amp, plus choice of common lamp ground or split lamp ground further extends its versatility.

## Switch/Indicator - Model 89, 89C



**Front Panel Servicing** - Model 89 and 89C Switch/Indicators are individually mounted units offering the same design features and advantages as the Series 8M and 8CM Matrix Mounted Systems. Both the switch/indicator module and the Sunlight Readable Display Pushbutton are plugged in and serviced from the front of the panel without use of special tools and without touching the behind the panel wiring. Choice of momentary or alternate switch action in either 2PDT or 4 PDT, with common or split lamp ground. Indicator only model has no switch action and is intended to serve as a warning light.

**Solder or Wire Wrap Termination** - Model 89 Switch/Indicator is a viable with choice of solder or wire wrap termination receptacles. Single plane wiring, with all lamp and switch terminals on the same level, greatly simplifies installation with saving in time and labor.

**Crimp Pin Termination** - Model 89C Switch termination receptacle accepts male crimp pin connectors on #20, #22 or #24 wire. Crimp pins are inserted at rear of switch assembly, same as with the Series 8CM Matrix System shown on page 8. Mating retainer holes in termination receptacle and female connectors in the switch/indicator module securely hold crimp pin connector and maintain proper electrical contact. Reduce wiring time to an absolute minimum with the Model 89C Switch/Indicator.

## Indicator Only - Model 82



**Solder/Spade Lug Terminations** - Model 82 Indicator has no switching action and is designed as a warning light only. Using the same Sunlight Readable Display Pushbutton as do the switches the Model 82 Indicator provides look-alike appearance when grouped in with Series 80 Switches. Compact design requires only 1.44" depth behind panel when mounted flush...even less when extended mounted for use with an overlay panel.

# SOLDER TERMINALS SWITCH - MODEL 87

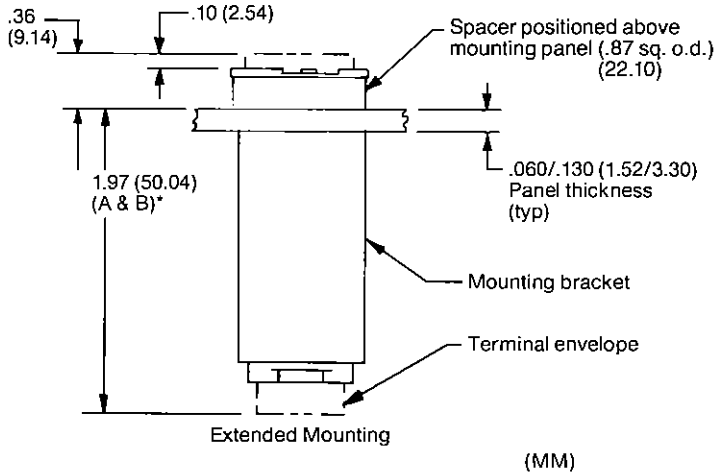
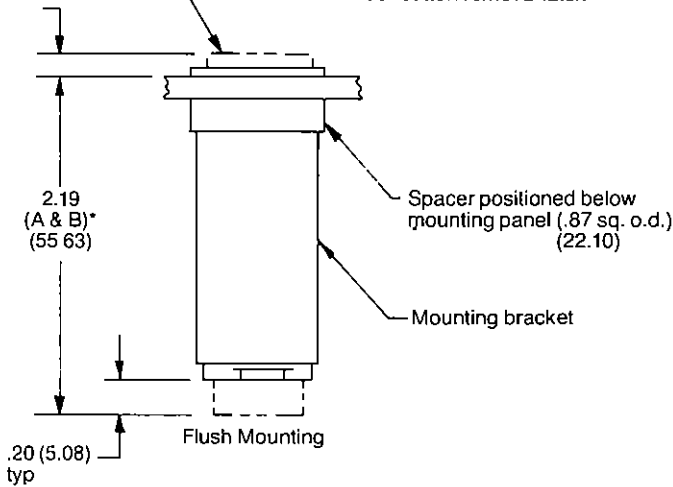
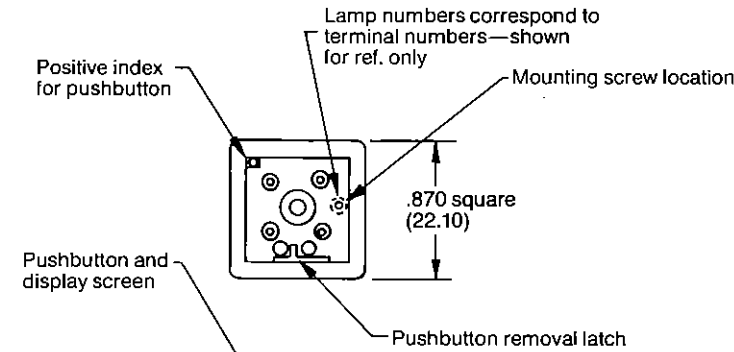

(MM)

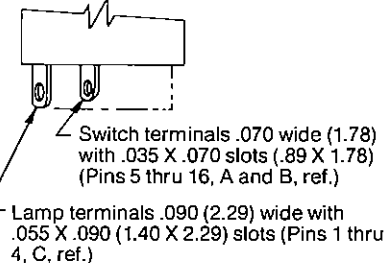
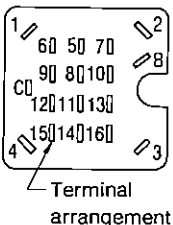
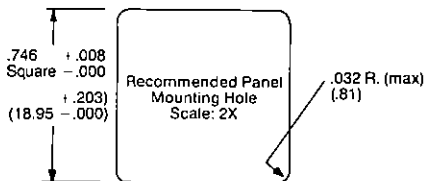

## Schematic

### Common Lamp Ground

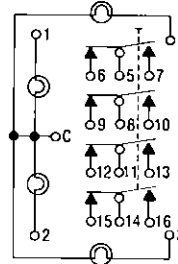

### Split Lamp Ground

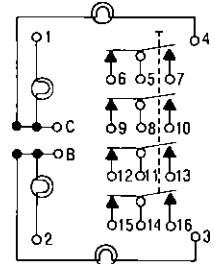

4PDT pushbutton switch schematic shown. For 2PDT omit terminals 8-13. For indicator only omit terminals 5-16. With momentary action switch terminals 6, 9, 12, and 15 are normally used.

## Specifications

- MECHANICAL:**
- A. Actuation Force, 3.5 ± 1.0 Pounds (1.59 ± .45kgms)
  - B. Actuation Travel, Type "A" & "B" = .20 inch max.
  - C. Weight, Type "A" & "B" = .075 lbs (34 gms) ± 10%
  - D. Life, 50,000 Mechanical Cycles
  - E. Return Force, 0.4 pound minimum (.181kg)
- ELECTRICAL:**
- A. Life at rated load, 25,000 Cycles, minimum
  - B. Contact Load Rating
 

Resistive	28 VDC	115 VAC
Inductive	2 Amps	2 Amps
Lamp	1 Amp	1 Amp
	.75 Amp	.75 Amp
  - C. Contact Resistance
 

Switch	Lamp
Initial	.025 Ohm, Max. 1.0 Ohm, Max.
  - D. Dielectric Strength, All terminals and case.
 

Sea Level, 1,056 VRMS
70,000 Feet-(21,341 meters) 450 VRMS
  - E. Insulation Resistance, 1,000 Megohms @ 500 VDC
- ENVIRONMENTAL:** Applicable military specification MIL-S-22885 Salt Spray, Moisture Resistance, Thermal Shock, Vibration, Sand and Dust and Fungus Resistance.

## Ordering Information

87	08	B	<b>TYPICAL PART NUMBER</b>
			A Momentary B Alternate Action Circuit Configuration 07 = 2PDT/CLG    09 = 2PDT/SLG 08 = 4PDT/CLG    10 = 4PDT/SLG Model #: 87, Solder Terminal Switch

Prefix "R" in front of model number (R87) denotes RFI/EMI shielded. Omit for non-RFI.

CLG = Common Lamp Ground  
SLG = Split Lamp Ground

# SOLDER OR WIRE WRAP TERMINATION RECEPTACLES - MODEL 89

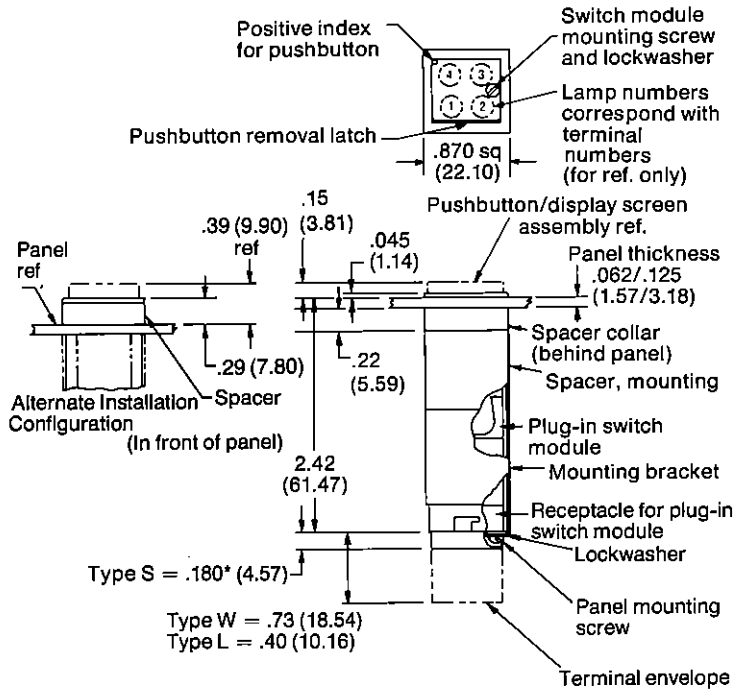
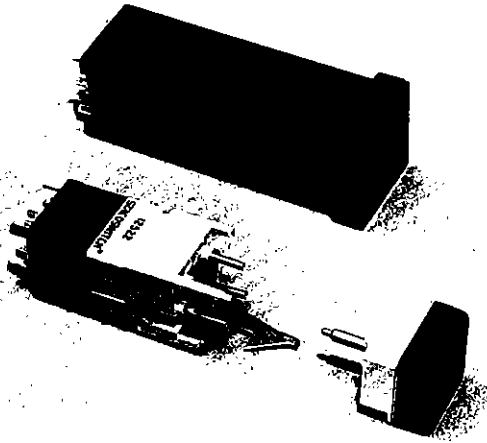

(MM)

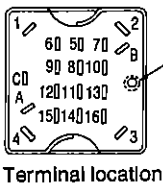

Threaded insert for switch module mtg. screw and for panel mtg. screw

Style W/L

Switch module plugs in here (typ)

Style S

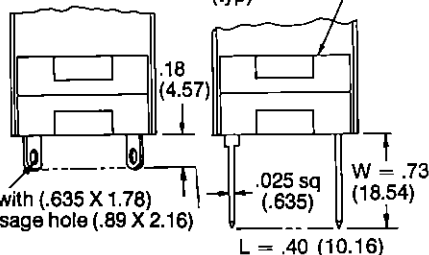

## Schematic

Common Lamp Ground

Split Lamp Ground

Solenoid Ground

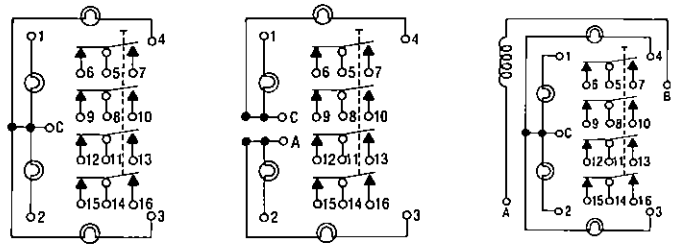

4PDT switch schematic shown. For 2PDT omit terminals 8-13. For indicator only omit terminals 5-16. With momentary action switch, switch terminals 6, 9, 12, and 15 are normally closed. Split lamp ground is not available with solenoid held switch.

## Specifications

CONTACT	RATING 28VDC	115 VAC
RESISTIVE	2 Amps	2 Amps
INDUCTIVE	1 Amp	1 Amp
LAMP	.75 Amp	.75 Amp
LOGIC LEVEL	5 Volts, 10 Milliamps	
Life at rated load	25,000 cycles min.	
Contact resistance, initial	Switch-1.0 Ohms max.	
Dielectric Strength	Sea Level-1,056 VRMS	
Insulation resistance	1,000 Megohms @ 500VDC	

### MECHANICAL

Actuation force	3.5 ± 1.0 Pounds
Actuation travel	.200 Inch max.
Life	50,000 mechanical cycles

**ENVIRONMENTAL:** Applicable military specification MIL-S-22885 Salt Spray, Moisture Resistance, Thermal Shock, Vibration, Sand and Dust and Fungus Resistance.

## Ordering Information

89 08 A - S

TYPICAL PART NUMBER

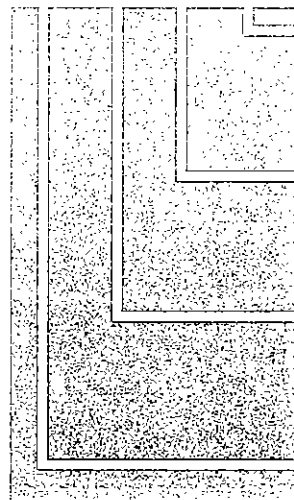

Receptacle Terminal Configuration (See sht. 3)

S = Solder Lug Type  
W = Wire Wrap Type .73 long  
L = Wire Wrap Type .40 Long

Switch Operation  
A = Momentary Action  
I = Indicator (Non-Switching, Lamp Circuits Only)  
X = No Module (Housing Only)

Circuit Configuration  
07 = 2PDT/CLG 12 = 2 PDT/SLG  
08 = 4PDT/CLG 13 = 4PDT/SLG  
00 = Indicator/CLG 14 = Indicator/SLG  
XX = No Module (Housing Only)

Basic Model Number: 89 Solder, WireWrap Termination

Prefix "R" in front of model number (R87) denotes RFI/EMI shielded. Omit for non-RFI.

CLG = Common Lamp Ground  
SLG = Split Lamp Ground

# CRIMP PIN TERMINATION RECEPTACLES - MODEL 89C

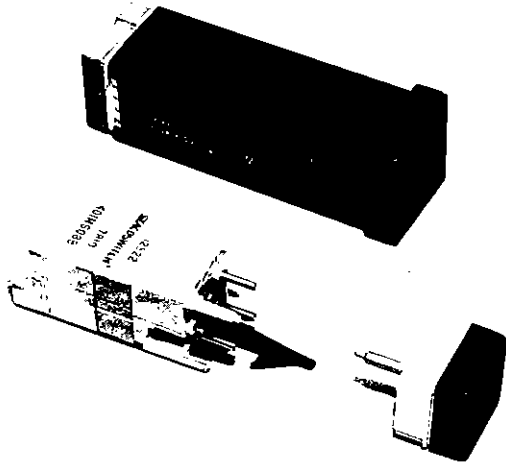

## Schematic

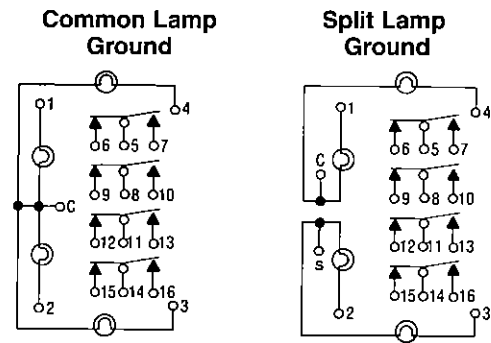

4PDT switch schematic shown. For 2PDT omit terminals 8-13. For indicator only omit terminals 5-16. With momentary switch action, switch terminals 6, 9, 12, and 15 are normally closed.

## Specifications

CONTACT RATING	28VDC	115 VAC
RESISTIVE	2 Amps	2 Amps
INDUCTIVE	1 Amp	1 Amp
LAMP	.75 Amp	.75 Amp
LOGIC LEVEL	5 Volts, 10 Milliamps	

Life at rated load	25,000 cycles min.
Contact resistance, initial	Switch-1.0 Ohms max. lamps - 1.0 Ohms max.
Dielectric Strength	Sea Level-1,056 VRMS
Insulation resistance	1,000 Megohms @ 500 VDC

## MECHANICAL

Actuation force	3.5 ± 1.0 Pounds
Actuation travel	.200 Inch max.
Life	50,000 mechanical cycles

**ENVIRONMENTAL:** Applicable military specification MIL-S-22885 Salt Spray, Moisture Resistance, Thermal Shock, Vibration, Sand and Dust and Fungus Resistance.

## Ordering Information

89C 08 A TYPICAL PART NUMBER

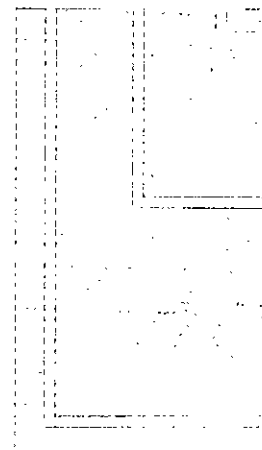

Switch Operation  
 A = Momentary Action  
 B = Alternate Action  
 I = Indicator (Non-Switching, Lamp Circuits Only)  
 X = No Module (Housing Only)

Circuit Configuration  
 07 = 2PDT/CLG  
 08 = 4PDT/CLG  
 00 = Indicator(Lamp circuits Only) CLG  
 XX = No Module (Housing Only)  
 09 = 2PDT/SLG  
 10 = 4PDT/SLG  
 11 = Indicator SLG

Basic Model Number = 89C, Crimp Pin Termination

Prefix "R" in front of model number (R87) denotes RFI/EMI shielded. Omit for non-RFI.

CLG = Common Lamp Ground  
 SLG = Split Lamp Ground

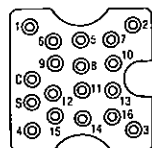
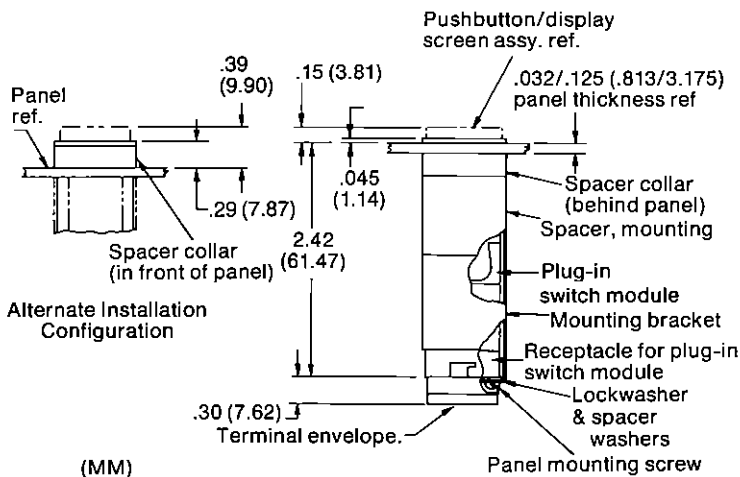
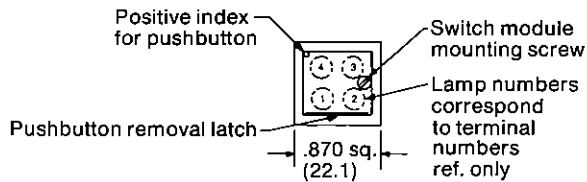

Receptacle shown is for 4PDT, split lamp ground switch. Receptacles supplied will match circuit configuration of the switch ordered with terminal retaining clips in the required crimp pin locations only. Receptacles mate with M39029/1-101 crimp pins.

# INDICATOR MODEL 82

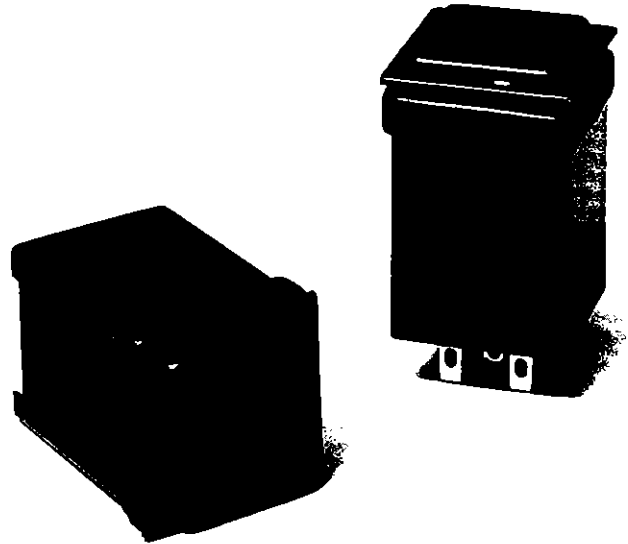
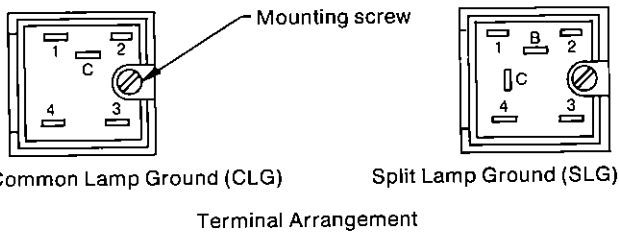
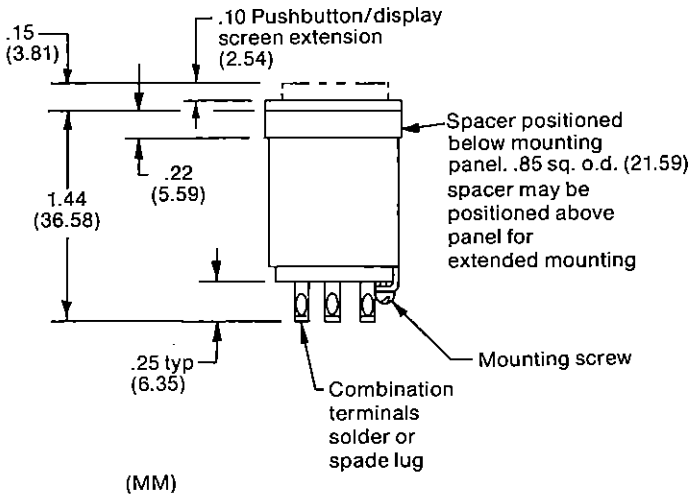
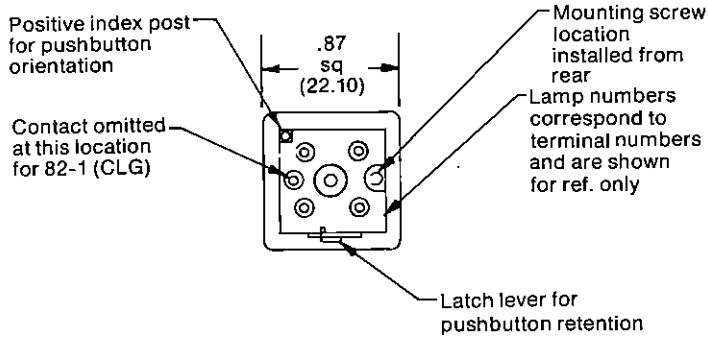

## Schematic

Common Lamp Ground Split Lamp Ground

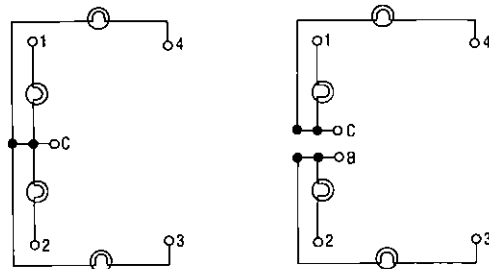

## Specifications

- MECHANICAL:** A. Weight, .044 lbs (20 gms) ± 10% (Incl. Pushbutton/Display)  
 B. Life, 1000 hrs. (minimum)
- ELECTRICAL:** A. Lamp Circuit Resistance, 0.5 Ohm max.  
 B. Dielectric, 1056 VRMS  
 C. Insulation Resistance, 500 Megohm
- ENVIRONMENTAL:** Applicable military specification MIL-S-22885 Salt Spray, Moisture Resistance, Thermal Shock, Vibration, Sand and Dust and Fungus Resistance.

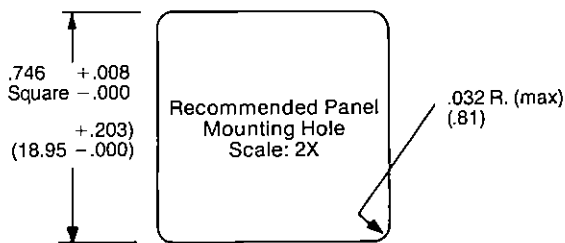

## Ordering Information

82	1	TYPICAL PART NUMBER
		1 = CLG = Common Lamp Ground
		2 = SLG = Split Lamp Ground
		Basic Model Number: 82,
		Solder/Spade Lug Termination

Prefix "R" in front of model number (R87) denotes RFI/EMI shielded. Omit for non-RFI.

# ACCESSORIES

## Barrier Frames



- For use with Series 80 Individually Mounted Switch/Indicators
- Provides vertical or horizontal separation between pushbuttons
- Prevents accidental simultaneous action of adjacent switches
- For individual mounting use double-end barrier
- For slot mount use one double-end and multiple single-end barriers
- Order square barriers as 15021-XX, rectangular as 15051-XX

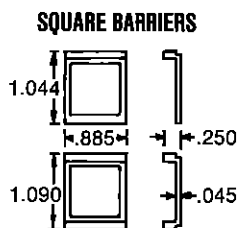

**SQ. SLOT MOUNTING CUTOUT**  
Cutout formula =  $.742 + (N-1)$   
"N" equals number of stations.

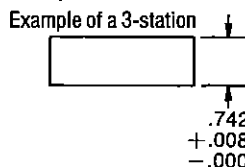

**PART NUMBERING**

**Part Numbering**

15021 1 2

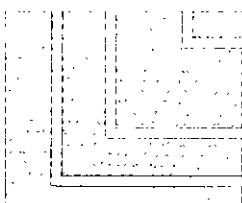

Basic Part number  
Color Black-1  
white-3  
Single end barrier -1  
Double end barrier -2

## Bezel Mounting

- Required for Dress Bezel Matrix Installation
- 5 per package
- Specify Part # 15098
- Required number of mounting screw w/locking cleat are included with complete assemblies.



## Pushbutton Guard

- Lift to allow switch actuation
- Prevents accidental actuation
- Pushbutton guard is transparent and spring loaded.
- Slips over switch housing upon installation
- Specify Part Number 15070 for Models 87,89,89C.

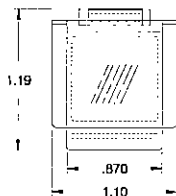

## Insulator Plugs

- Close off unused terminal opening in termination receptacles for Models 8CM or 89C.
- Specify StacoSwitch Part Number 15177 for MS27488-A20



## Insertion And Removal Tool

- Inserts or removes connector wire with crimp pins attached
- Specify Part Number 15178 for M81969/14-10



## Crimping Tool And Positioner

- Attaches male crimp pins to wire for Models 8CM and 89C
- Both Crimping Tool and Turret are required
- Specify Part Number 15179 for M22520/1-01 Crimping tool
- Specify Part Number 15180 for M22520/1-02 Turret

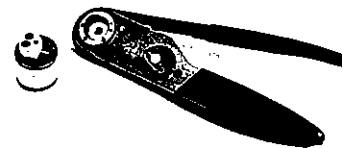

## Male Crimp Pins

- Use for connection to #20, #22 or #24 wire with Models 8CM and 89C
- Specify Part Number 15176 for M39029/1-101 Male Crimp Pins

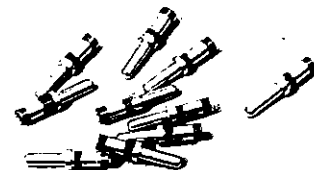

## Termination Receptacle Model 8M

For use with Models 8M and 89 Switch/Indicator Modules  
To order use part number code below

15066- X X

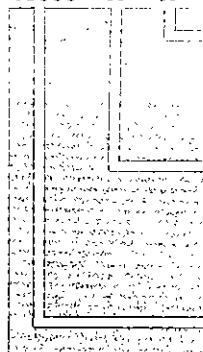

S = Solder  
L = Wire Wrap, .25 sq., 40 Length  
W = Wire Wrap, .025 sq., 73 length  
P = Printed Circuit, .025 sq., 125 length

-1 = 4 PDT;                   -2 = 2PDT  
-3 = Indicator, split lamp ground  
-4 = 4PDT, magnetic held or split lamp ground  
-5 = 2PDT, magnetic held or split ground  
-6 = Indicator

Basic Part Number

## Model 8CM Matrix System Termination

For use with Models 8CM and 89C Housing.  
To order use part number code below

15073 X

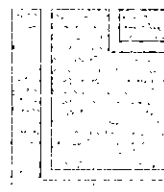

01 = Indicator/CLG  
02 = 2PDT/CLG   03 = 4PDT/CLG  
04 = Indicator/SLG  
05 = 2 PDT/SLG   06 = 4PDT/SLG

Basic Part Number

# CONTROLLERS

## Dimmer

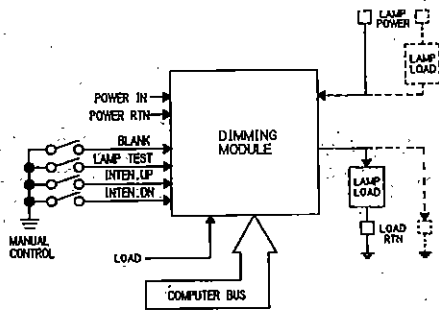

## Interface Controller

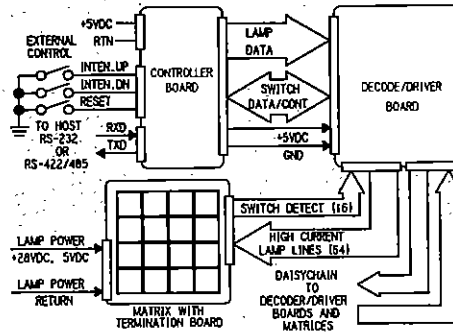

**FOR DIMMING OF BOTH LED AND INCANDESCENT DEVICES**

**FOR MULTIPLEXING AND CONTROL OF LIGHTING AND SWITCH FUNCTIONS**

- LED and Incandescent Dimming
- 16 Levels of Brightness Control
- Full Brightness
- Full Blank Lamp Test
- Remote UP/DOWN Input
- 4 Bit Digital Input
- Sourcing or Sinking
- Full Mil Spec Construction
- Specify Part Number DDM111
- Catalog Number GC - 6/9

- Control of Up to 256 Outputs (Lamps)
- Control of Up to 64 Inputs (Switches)
- Receipt and Execution of Host Commands
- Power Up Diagnostics
- LED or Incandescent Lamp ON/OFF Control
- 32 Levels of Brightness Control
- Mil Spec or Industrial Versions
- RS232, RS422 or RS485 Compatible
- Specify Part Number IFC211
- Catalog Number GC - 6/9

# STACO SWITCH

*A Components Corporation of America Company*

1139 Baker Street • Costa Mesa, CA 92626-4191

Fax: 714.549.0930

Telephone: 714.549.3041