

	NAME	DATE
ORIGINATOR	F.TU	DEC. 16, 2010

TECHNICAL BULLETIN TB-213

TECHNICAL BULLETIN FOR 4X4 KEYPAD, M2/0478

**Note: Using LED P/N: 13785-002
Temperate Range from -40°C to +80°C**

The information and design disclosed herein was originated by and is the property of STACO SYSTEMS, INC. STACO SYSTEMS, INC. reserves all patent, proprietary, design, manufacturing, reproduction, use and sale rights thereto, and to any article disclosed therein, except to the rights that are expressly granted to others. The foregoing does not apply to vendor proprietary parts. ©Copyright Staco Systems, Inc. 2010.

PART NO.

TB-213

SHEET 1 of 4

TB-213

1.0

Revision Log

Rev.	E. R. No.	Revised By	Checked By	Approved By	Rel. Date
1.0	ER-42323				

CAGE CODE 12522	PART NO. TB-213	REV. 1.0	SHT. 2
--------------------	--------------------	-------------	-----------

The keypad may be lighted using various voltage sources as long as a current limiting circuit is provided. The recommended current limiting circuit includes user-supplied resistors as shown on the following figures. The V_S is the voltage source, and pins 1 through pin 17 are the pins of green and red LED lighting connectors.

The recommended resistor value for the green LED lighting connector (R_G), resistor value for the red LED lighting connector (R_R), minimum resistor power rating for the green LED lighting connector (P_{RG}), minimum resistor power rating for the red LED lighting connector (P_{RR}) for a given power supply voltage source (V_S) are shown on the following tables. Also shown are the minimum power supply powers rating (P_S).

If the voltage source is not listed on the tables, P_S , R_G , R_R , P_{RG} , and P_{RR} are determined by evaluating the equations which follow. The following equations are derived for a lighted 4X4 keypad that has sixteen (n) pushbuttons (LEDs) with 20 mA forward current (i) per LED, 2.2 V green LED forward voltage (V_{LG}), and 2.0 V red LED forward voltage (V_{LR}).

Recommended Power Supply and Resistor to Individually Light Each Pushbutton

A pushbutton LED is lighted by grounding its cathode.

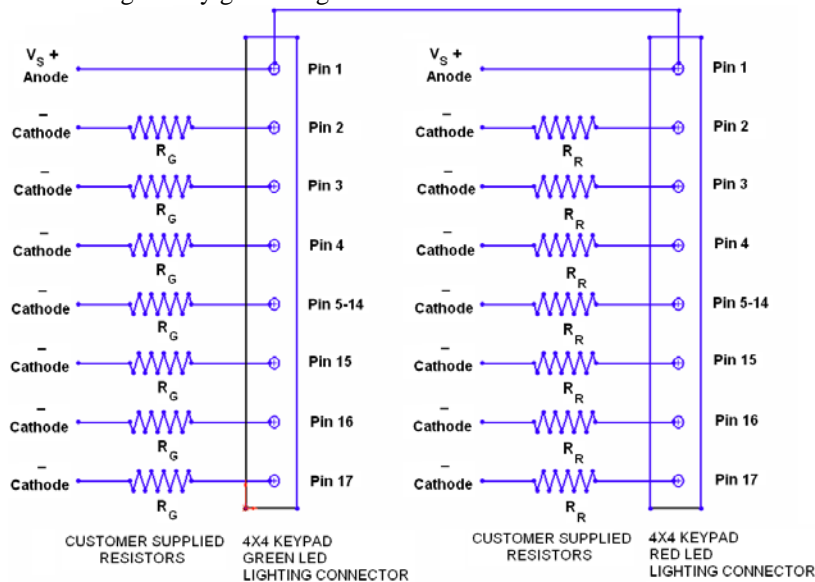

Resistors to Light Individual Pushbutton Green or Red

Power Supply and Resistor to Light Individual Pushbutton Green or Red									
Power Supply		Resistor for Green LED		Resistor for Red LED		Pushbutton		Green LED	Red LED
V_S (V)	P_S (W)	R_G (Ω)	P_{RG} min (W)	R_R (Ω)	P_{RR} min (W)	TOTAL (n)	i (A)	V_{LG} (V)	V_{LR} (V)
5	1.60	140	0.056	150	0.060	16	0.02	2.2	2.0
12	3.84	490	0.196	500	0.200	16	0.02	2.2	2.0
14	4.48	590	0.236	600	0.240	16	0.02	2.2	2.0
28	8.96	1290	0.516	1300	0.520	16	0.02	2.2	2.0

Power Supply and Resistor Equations to Light Individual Pushbutton

$$P_S = niV_S ; R_G = \frac{V_S - V_{LG}}{i} ; R_R = \frac{V_S - V_{LR}}{i} ; P_{RG} = i^2 R_G ; P_{RR} = i^2 R_R$$

CAGE CODE
12522

PART NO.

TB-213

REV.
1.0

SHT.
3

Recommended Power Supply and Resistor to Simultaneously Light All Pushbuttons

NOTE:

Since the anodes of the green LEDs and the anodes of the red LEDs are tied together to pin 1 green LED lighting connector and pin 1 red LED lighting connector, each current limiting resistor has to be placed on the cathode side of the connector. The pushbuttons are lighted by bringing the cathode to ground.

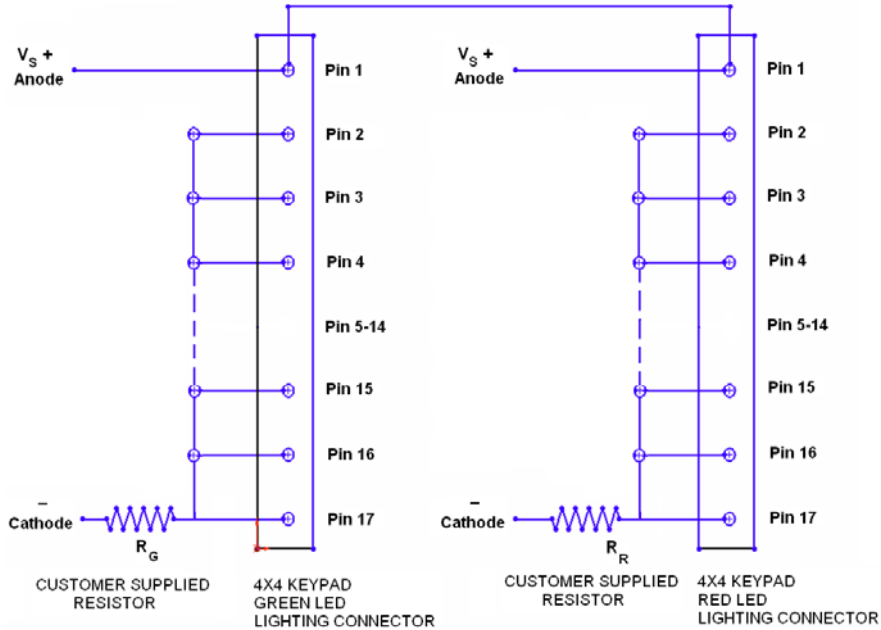

Resistors to Light All Pushbuttons Green or Red

Power Supply and Resistor to Light All Pushbutton Greens or Red									
Power Supply		Resistor for Green LED		Resistor for Red LED		Pushbutton		Green LED	Red LED
V_S (V)	P_S (W)	R_G (Ω)	P_{RG} min (W)	R_R (Ω)	P_{RR} min (W)	TOTAL (n)	i (A)	V_{LG} (V)	V_{LR} (V)
5	1.60	8.75	0.896	9.375	0.960	16	0.02	2.2	2.0
12	3.84	30.63	3.136	31.250	3.200	16	0.02	2.2	2.0
14	4.48	36.88	3.776	37.500	3.840	16	0.02	2.2	2.0
28	8.96	80.63	8.256	81.250	8.320	16	0.02	2.2	2.0

Power Supply and Resistor Equations to Light All Pushbuttons

$$P_S = niV_S ; R_G = \frac{V_S - V_{LG}}{ni} ; R_R = \frac{V_S - V_{LR}}{ni} ; P_{RG} = (ni)^2 R_G ; P_{RR} = (ni)^2 R_R$$

CAGE CODE	PART NO.	REV.	SHT.
12522	TB-213	1.0	4